

VEHICLE MAINTENANCE

Introduction

1.0 Introduction

The servicing of the automobile has also changed greatly to keep in step with the engineering advances of the industry.

The tools and equipments which the early mechanic used were poor compared to today's standard, and in many cases were made by the mechanic. Today's automotive mechanic is well trained and works in a clean, bright, well-ventilated, specially designed automotive service centre.

A thorough knowledge of the parts and understanding of the mechanisms are essential in order that faulty conditions in any part of automotive mechanism may be detected and corrected. As a result, the mechanic must possess the knowledge, skill, and experience in this field to be successful.

Service Station

A service station is a place where in addition to care of the motor vehicle like mechanical service and minor repairs, petrol is supplied, cars are lubricated, and cleaned, washed and other types of simpler services that are required daily are performed. In general it includes a number of sections like garage general it includes a number of sections like garage general service, mechanical service, major repair shop, tire shop, paint shop, body shop.

A service station in addition to the equipment available in a garage is usually run in conjunction with a sales agency for a particular type of motor vehicle to provide comprehensive repair service for that particular vehicle.

The equipment available in a general garage will be added with specialized equipment like lifting tackle, and different types of jigs, fixtures and tools specially designed for checking, adjusting and repair of particular type and make of the vehicle. A service station may consist of a machine shop having a lathe, drilling machine etc.

In case of big service station special types of machines like crank shaft grinding machine, valve refacer, surface grinder, reborer and boring machine, and brake drum lathe also will be equipments.

1.2 Layout of a typical garage, service station and specialist repair shop

The internal layout of a garage should be such as to make it water proof, clean and spacious to provide sufficient space for small work benches, to storage and repair benches. Following considerations should be made in the layout of garage and service stations:

- (i) To provide light to the work benches, opening the windows should be provided at the proper place.
- (ii) To keep the floor easily cleanable, it should be a smooth concrete floor with a surface cleaning compound.

- (iii) The doors are provided as many members as required for easy flow of men and materials.
- (iv) The electrical control should be accessible to the operators.
- (v) To form a neat storage for hanging tools, hooks or screw eyes should be provided on the peg boards.
- (vi) To provide a deposit of waste material.

(a) Layout of typical garage and service station

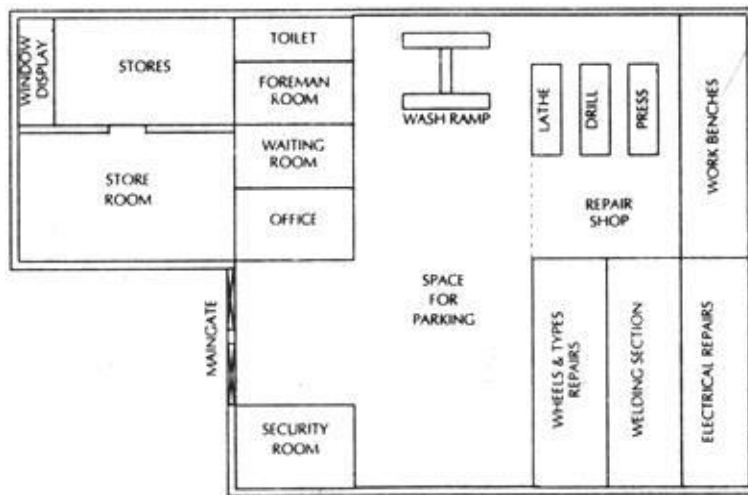

Fig 1.1 Layout of Typical Garage

(b) Layout of modern service station : They layout of service station is shown

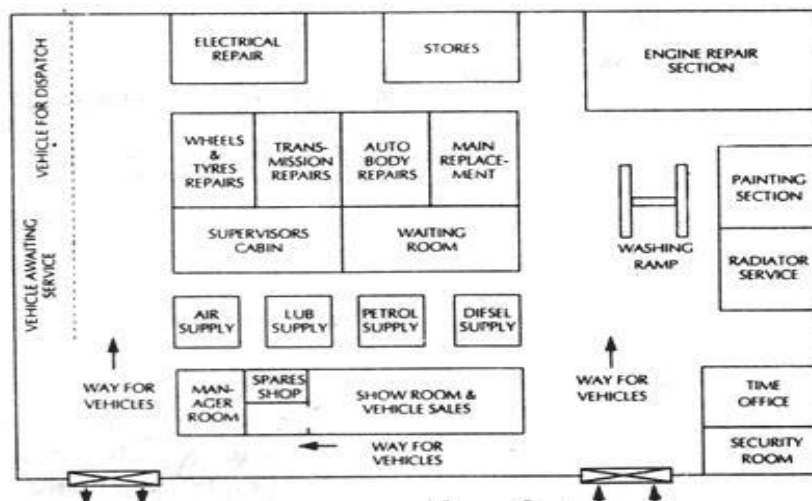

Fig 1.2 Layout of modern service station

1.3 Tools And Equipment For Auto Workshop

Many of the tools and items of equipment are necessary to enable the motor vehicle workshop to cope with the wide variety of servicing and repair work. The following is a list of tools and equipment in the auto shop.

Hand tools : Many kind types and sizes of tools are used in automobile work.

1. D.E. spanner set : These are the most commonly used type of spanner in garage. The opening should be the right size to fit the nut or bolt. If the spanner opening is too large, it could round off the corners of the hex. These make the use of the proper spanner more difficult. These spanners are available in different sizes ranging from 6 to 32mm.

2. Ring spanner : In ring spanners the end openings completely enclose the nut or the bolt head, so that they do not slip and cause damage. Further, the end holes in the ring spanners are twelve sided, because of which they can be used in restricted spaces, since the nut or the bolt head can be worked upon even when the swing of the spanner is restricted to 15.

3. Tubular spanner : These are also used for the same purpose as ring spanner. It will be like a long tube having hexagonal ends at each end of different size. They may vary in size from 8mm to 32mm. It can be used where double end and ring spanner cannot be used.

4. Socket spanners : These types of spanners are useful in restricted spaces where common types of spanners cannot be used. They consist of sockets of different sizes which can be used with various types of handles. The handles have projection at one end around which the sockets fit. One type of handle has a universal joint at the projection end which makes it possible to work with the handle at an inclination with the socket. A ratchet handle is also available which obviates necessity of lifting of the socket from the nut or the bolt head.

5. Adjustable wrenches : This wrench has jaws that can be adjusted to fit nuts and bolt heads of various sizes. These types of wrenches have advantage that these can be suitable for a large number of nut and bolt head sizes.

6. Torque wrenches : Important nuts and bolts in automobile work have to be tightened with a specified amount of torque, because excessive torque may result in their breakage while less torque they will remain loose. This is made possible by a torque wrench. It is a specialised form of socket spanners.

-

7. Screw driver : The screw driver is used to drive, or turn screws. The most common type has a single flat blade for driving screws with slotted heads. There are also the Phillips head and reed, and prince screw drivers.

8. Hammers : A medium weight ball pen hammer is the one commonly used in automobile work. It should be gripped on the end of the handle. When you swing the hammer, the face should strike the object squarely, and not an angle.

9. Pliers : pliers are a special type of adjustable wrench. The two legs move on a pivot so that items of various sizes can be gripped. There are two types gripping pliers and cutting plier.

10. Pullers : Pullers come in a variety of types and sizes and are used to remove wheels, gears and bearing from shafts from housings. Each pulling operation differs from the other, and care must be exercised to prevent damage to the parts during pulling.

11. Spark plug spanner : For removing or tightening spark plugs.

12. Feeler gauge : For measurements such as valve clearance, spark plug gap, contact breaker gap etc., we use feeler gauges which are simply blades of different thickness.

13. Valve spring compressor : Valve spring compressors or lifters are used to compress the valve spring to facilitate the removal of the valve retain lock or keeper from the valve stem.

14. Piston ring compressor : Piston ring compressors are places around the piston covering the rings. As the compressor is tightened, it compresses the piston rings into their grooves on the piston. Then the piston and rod assembly is installed into the cylinder.

15. Piston ring expander : It is generally use to expand and remove the piston rings from their grooves without breaking.



D.E. Spanner



Ring Spanner



Fig. 1.3 Adjustable Spanner



Fig. 1.4 Screw Driver



Fig. 1.5 Ball Pen Hammer

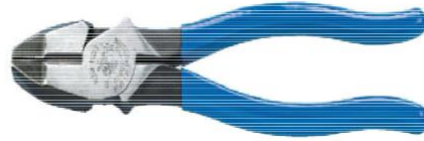

Fig. 1.6 Cutting Plier



Fig. 1.7 Socket Spanners



Fig. 1.8 Torque Wrench



Fig. 1.9 Valve spring compressor



Fig. 1.10 Piston Ring Compressor



Fig. 1.11 Piston Ring Expander



Fig. 1.12 Puller



Fig 1.13 Feller Gauge

Service station equipments

A large number of different types of equipments are required in a garage or service station for carrying out different types of repair works. Different types of equipments are required to cope up with the wide variety of work to be done can be classified as under.

Special equipments for service station

1. Compressed air plant
2. Car washing machine
3. Lifting tackles
 - (a) Hydraulic jack
 - (b) Car lift
 - (c) Axle stands
 - (d) Jib crane
 - (e) A chain hoist
4. Chassis dynamometer
5. Wheel balancer
6. Tire remover
7. Brake drum lathe
8. Brake shoe lining riveting machine
9. Spark plug tester
10. High pressure grease gun

11. Wheel alignment gauges

12. Degreasing plant

Special equipments for engine repair:

1. Crankshaft grinding machine

2. Cylinder head surface grinding machine

3. Line boring machine

4. Connecting rod big end bearing boring machine

5. Cam shaft grinding machine

6. Valve refacer machine

7. Hydraulic press

8. Cylinder boring machine

9. Cylinder honing machine

10. Connecting rod rebabbiting jig

Special equipments for compression engines

1. Bench nozzle testing and cleaning equipment

2. Fuel injector tester

3. Fuel pump tester

4. Nozzle and needle grinding and lapping machines.

Power tools : Power tools are increasingly used in modern automated auto workshops. They are operated by pneumatic, electric, hydraulic powers. Their use envisage quicker, effortless and efficient service.

Pneumatic Nut and Bolt Tightener : It tightens and loosens the nuts and bolts in no time. This is a portable machine whose working end can be changed to suit different sizes of bolts and nuts.

Valve Refacer : It is used to recondition the weared and worn valve faces. On employing an attachment, it can be used to grind valve stem, tappet and the rocker arm.

Portable Drilling Machine : This is an electrically powered machine which is used to make holes whenever required. It can be taken conveniently to any area of repair since it is handy, compact and portable.

-

Drill Stand : It is used to mount the drill machine. The job to be drilled can be placed and clamped on its base. The height of the drill machine can be adjusted suitably to accommodate jobs of different heights. For this purpose the grooves are cut on its vertical stand. The height adjustment is done by means of a lever and mechanical linkage.

Polisher and Sander : This is an electrically powered machine used to rub the burrs from the surfaces of components, and then polish it to super finishing accuracy. The standing is accomplished by means of emery paper or emery cloth of coarse grade while the fine grade is used for polishing.

Portable Grinder : This is used to grind the rough surfaces, unwanted projections, pro-truding corners etc. being sturdy and handy, it can be taken to any remote, restricted and less accessible areas for repairing.

.

Important factors to be considered while location service station-

Easily approachable, idle sight, availability of the vehicles in the surroundings, availability of qualified and experience labour force (mechanics), provision of proper drainage, sanitation system.

.

Major Equipment For Service Station

2.1 Car Washing Machine

Regular chassis washing of both cars and commercial vehicles to remove grease, oil, mud and other corrosive deposits is most essential. This type of cleaning is a time representative of preventive maintenance. This is easily done by a spray of water with a solvent, at high pressure (above 25 kg/cm^2).

Car washer consists of a pump which is driven by a electric motor. The pump sucks water from a well or from water tank filled beneath it and delivers to the nozzle through a pipe of hoses with high pressure. There are two types of car washers as follows.

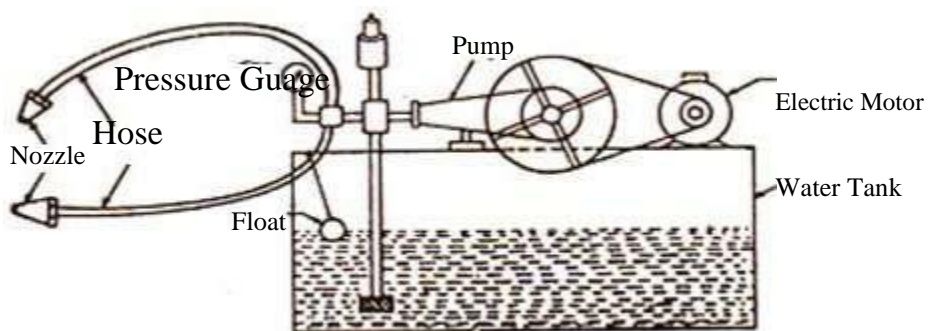

Fig 2.1 Car Washing Motor

That provided with single hose which can be used to wash only one vehicle at a time

1. That provided with twin hoses which can be used to wash two vehicles at a time. The nozzles are adjustable, so that the delivery of water can be regulated at variable force from fine spray to solid jet.

Automatic Washing-

The automatic car wash machine has a three horse power pumping station which pumps up to 100ltrs of water per minute through 15 numbers of nozzles, 12 of which spray as a pre-wash arch which washes tires, wheels and rocker panels and rest three nozzles sprays on back top brush. The machine dispenses a specially formulated foaming, high pressure chemical during a pre-wash pass which is applied along with high pressure wash.

The high pressure spray automatically adjusts to the vehicle's dimensions by the use of P L C based control panel and lastly, high pressure air blowers maintain the best air-steam helps to dry the complete vehicle surfaces.

The features and benefits of

1. Washes all shapes, sizes and configurations of vehicles.
2. All brushes are made of extremely durable at soft bristles that are carefully hand-woven.
3. There is an intensified rear wash programme to effectively double wash the backs of vehicles.

2.2 Vehicle hoist

In a big workshop, a hydraulic hoist becomes necessary to facilitate the service work. Different types of hoists are used in automobile workshop. They are.

- (i) Drive on lift or single post hoist
- (ii) Two post hoist
- (iii) Four post hoist
- (iv) Six post hoist.
- (v) Generally single post hoist as shown in fig 2.2 used in workshop.

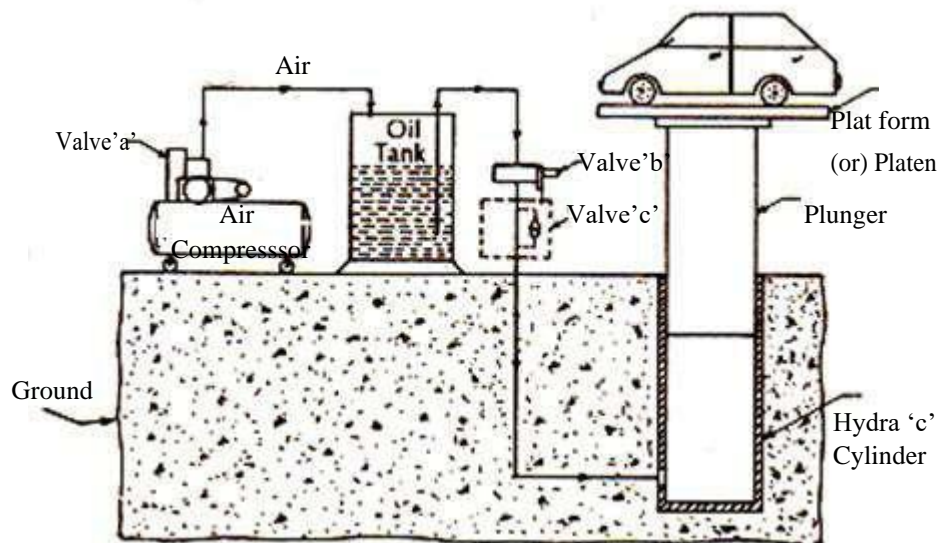

Fig 2.2 Vehical Hoist

The lift or hoist consists of a platform which is fixed on the top of the ram working in a hydraulic cylinder. Normally the platform will be at ground level and will be raised with the help hydraulic pressure applied on the ram.

When valve 'A' is actuated, high pressure air from the compressor acts on an oil surface in the reservoir. Oil rushes through piping into a hydraulic cylinder via another pilot valve 'B'.

Pressured oil entering the bottom cylinder, lifts the plunger up. An automobile stationed on a platform attached to the plunger is thus lifted up, giving access for washing and servicing.

To lower the vehicle, the valve is brought to the original position. Due to the self-weight of the vehicle, platform, etc., and the plunger descends gradually, pushing back oil into the reservoir through the restriction valve 'C'. The speed at which the vehicle or platform is lowered can be adjusted by the restriction of the unidirectional flow regulator 'C'.

2.3 Air Compressor

Air compressors are used to compress the air which can be used for a number of purposes like washing of vehicle, cleaning of engine, spraying of lubricating oil, spraying of paint, tyre inflation, greasing a vehicle, for lifting hoist, for pneumatic grinder, for spark plug cleaning, etc.

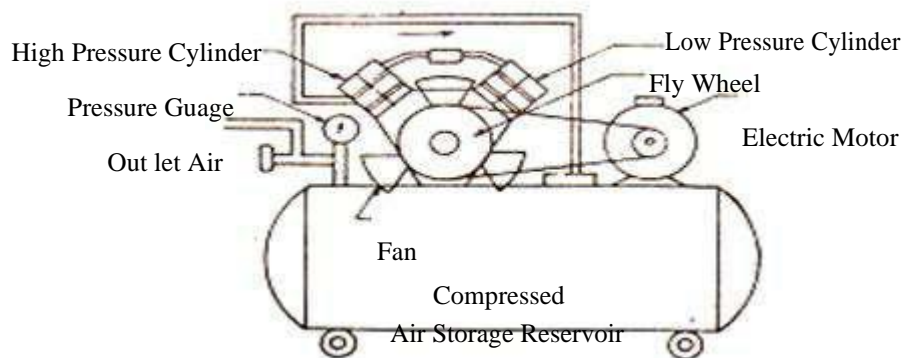

Fig 2.3 Air Compressor

An air compressor is shown in fig 2.3. It can be compared with the working of a petrol engine or any other engine. The air compressor is coupled to an electric motor.

An automatic pressure controller is provided between the motor and the main current line, to break the circuit when the pressure inside the air tank reaches a maximum value.

The compressor piston draws air into the cylinder during the suction stroke through the inlet valve. As the piston moves upward during its next stroke, the inlet

-
valve closes and the air gets compressed and delivered to the air tank through outlet valve. One pressure gauge is fitted on air tank for observing the filling position.

2.4 Lubrication Equipments

Lubrication is the most important factors in the maintenance of the car. If this is neglected in any way the mechanism wears more rapidly and troubles are apt to occur. On the other hand liberal lubrication means long life and efficient running, with general freedom from trouble.

To lubricate certain components beneath the chassis with the help of lubrication equipments, grease guns and high pressure lubrication equipments are used.

Grease guns

Grease guns are used to lubricate the chassis components with grease. Several types of hand operated grease guns are available. They are.

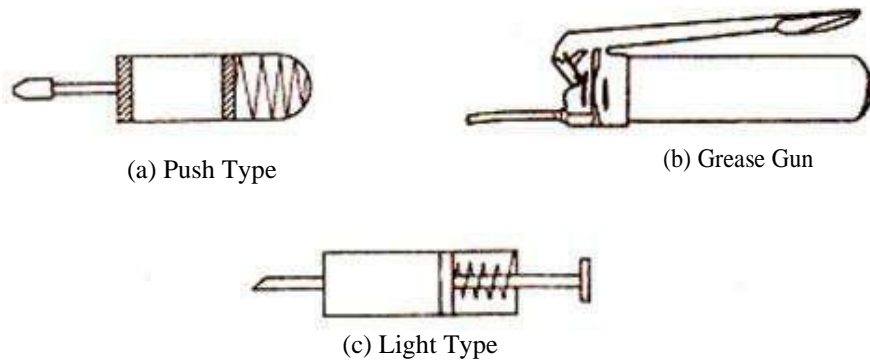

Fig 2.4 Grease Gun

- (a) Push type
- (b) Grease gun
- (c) Light type, and
- (d) Bucket type

Hand and compressed air- operated

Depending upon the type of lubricant and pressure used the first three types of hand operated grease guns.

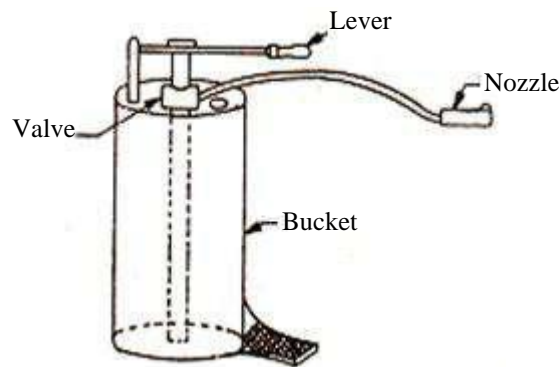

Fig 2.5 Hand Operated Bucket Type Lubricator

Push type grease guns consist of a cylindrical barrel one end of which is fitted with a nozzle cup, a piston moves inside the barrel. The piston rod assembly cap is screwed tightly to barrel. To and fro movement of piston rod develops pressure inside the barrel. When lever is depressed grease comes out of the nozzle under high pressure.

Bucket type grease gun valve will be operated by a lever which sucks grease from the central tube and delivers through outer tube and hand nozzle. It is shown in fig 2.4

High Pressure Lubrication Equipment

High pressure lubrication equipment is shown in fig 2.4. it is similar to hand operated grease gun but operated under air pressure.

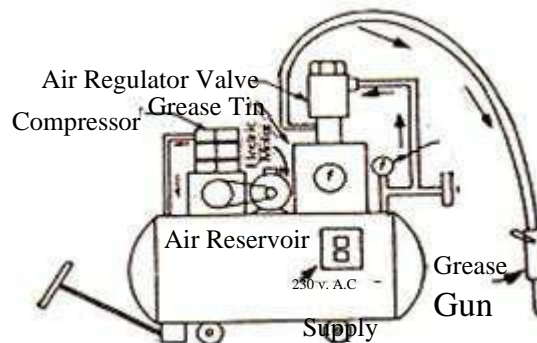

Fig 2.6 High Pressure Lubricator

A separate container for grease filling is arranged on compressor tank and valve is fitted on it. Grease gun pipe and air compressor pipe are connected to valve. It is necessary that lubricant should be forced into the bearing until the old lubricant is forced out new lubricant appears

Automobile Engine Reconditioning Equipment

3.0 Introduction

Engine reconditioning is a method of engine servicing. Some companies set up special engine disassemble and rebuilding lines. They bring in old, worn engines, disassemble them completely, repair or replace all worn parts and then completely, recondition the engine using the old parts that are still in good condition. By reconditioning the engine becomes as good as new. There are many machine operations performed on engine parts. Good machining will give like new quality, while poor machining can ruin salvageable parts. Hence care should be taken to get the parts machined from well equipped machine shop which has a reputation of quality work.

Different types of equipments are required for reconditioning of engine. They are cylinder reboring and honing equipments, cylinder ridge reamer, line boring machine, valve reconditioning equipment, crankshaft grinder etc.

3.1 Degreasing Plant

A layer of oil, grease and dirt gets coated to the engine parts with passage of time and usage. Before performing servicing of the engine (i.e. disassembly, inspection and measure), the unwanted layer should be removed. This can be done by hand cleaning or by means of certain cleaning methods. For small parts, where only a limited number is concerned, a paraffin bath can be used, the parts being brushed or scrubbed with a stiff bristle brush to get rid of hard deposits.

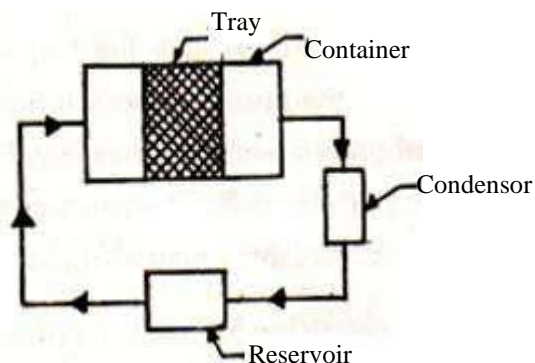

Fig 3.1 This type of degreasing plant is shown

For the larger components it is usual in small workshop to use a hot caustic soda bath or steam bath. The caustic soda should not be used for aluminium alloys since it has a masked chemical action-paraffin or steam bath is recommended instead. In a larger workshop special chemical degreasing plant is employed to clean engine parts. Usually, the dirty parts are placed in a large perforated tray or wire basket and exposed within a tank like contains to the vapour of the heated trichloroethylene. It is a cheap and powerful solvent and is non-inflammable. A condenser is used to condense the vapours and return to the reservoir for the further use.

3.2 De-Carbonizing

Carbon is deposited in cylinder due to rich mixture supply, use of wrong grade oil, unnecessary idling, too much oil. Poor fitted piston and piston rings.

Deposition of carbon causes engine knockings, missing of explosions and burnt valve resulting in loss of power. The carbon collector at the valve head make the head unable to dissipate heat resulting its burning or warping sometimes. The carbon depositing in between valve and seat and impact of valves causes pits in the seat. Therefore, a loss of compression, reduced power, greater fuel consumption are caused. There, are in general three methods of decarbonising or decoding-

1. Scraping method
2. Oxygen decarbonising method
3. Chemical method of decarbonising.

1. Scraping method : The scraping of the carbon is done usually by hand scraping with the help of tools. To remove carbon from the piston, remove it from the cylinder. Now scrap the carbon removing brushes may be fixed in the chuck of an electric portable drill. To clean valve grinder, valve stems etc., special wire brushers may also be use.

2. Oxygen decarbonising method : It is the process of removing carbon from the inside of the cylinder and head of the piston without removing the cylinder head by means of an oxygen flame. The equipment consists of an oxygen tank fitted at an initial pressure of 156kg/cm^2 . The oxygen is applied to the combustion space by inserting a flexible delivery jet through a valve plug orifice or spark plug hole by slightly bending or turning it. The oxygen flame will burn away all the carbon deposits completely.

3. Chemical method of decarbonising : The chemical method consists in injecting into each cylinder head trough the spark plug hole a special chemical in liquid form. The engine should be in a warm condition so that the liquid can act more efficiently, after standing for about 12 hours the carbon is loosened, so that upon starting up the engine it is blown out of the exhaust pipe.

3.3 Cylinder Ridge Removal

Cylinders should be inspected for the ridge at the top which shows the upper limit of piston travel in cylinder, it is shown in Fig 3.2

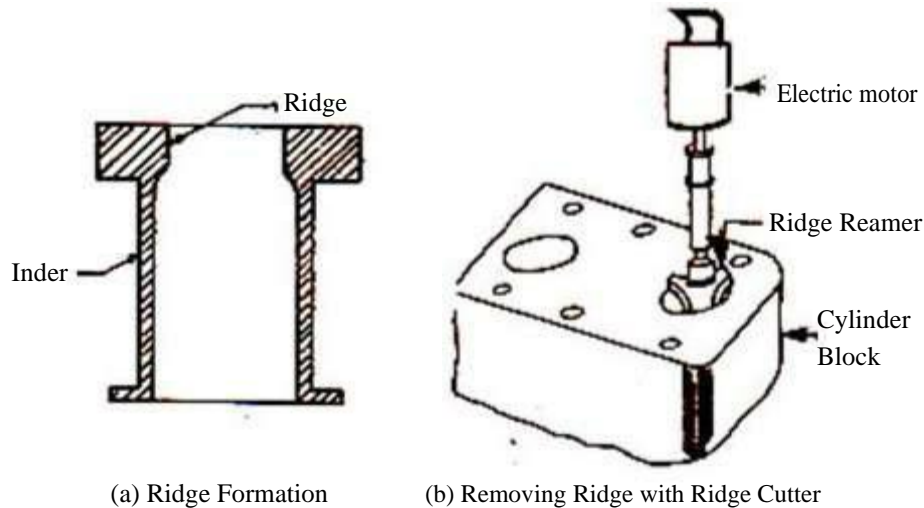

Fig 3.2 Cylinder Ridge Removal

(a) This ridge if found must be removed before proceeding further, because otherwise the rings are liable to break once the attempt is made to take out the piston rod assembly from the top. The ridge is removed by means of a special ridge reamer is shown in Fig 3.2

(b) However, care should be taken not to remove any excess metal from the cylinder. Further before starting ridge removal, rotate the crankshaft so that piston of the cylinder being worked upon is at the bottom of the stroke. In this position stiff clean in the cylinder.

Rider is consist of column, spindle head, cutter and level table. The cylinder block is placed over the table below the spindle. The cutter is centered with the cylinder, then speed and feed for the speed is selected and the machine is started. This procedure is repeated until the ridge is removal. This procedure is repeated for other cylinders also.

3.4 Cylinder Reboring Method

In recent practice the method of truing worm cylinders with the baring bar has become widely used on account of its rapidity and precision. Reboring is done on special machines, it is shown in Fig 3.3.

In this machines uses a single point tool (or) cutter which is set to the exact diameter required with special micrometer. The cutting edge is sharpened on a revolving disk, using a mixture of diamond dirt and oil. The cutter blade shaft is mounted inside a column which moves up and down its housing in the mixed part of the machine, for tool feeding purpose. The cutter is driven at low speed by an electric motor mounted on the machine.

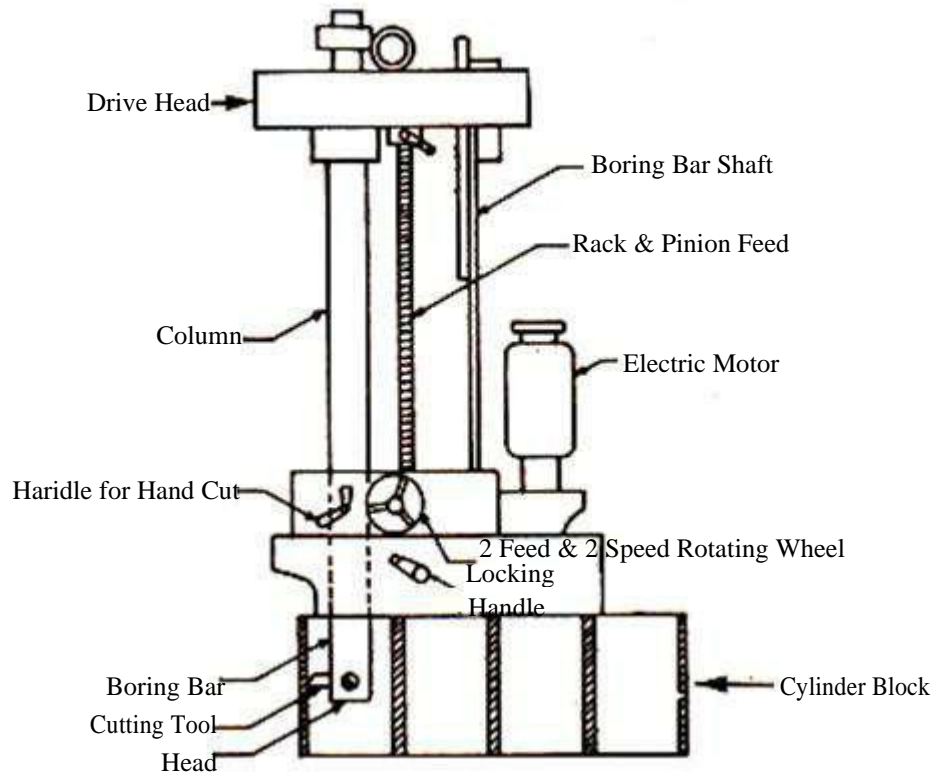

Fig 3.3 Cylinder Reboring machine

The top surface of the cylinder block is thoroughly cleaned and the boring bar set at one of the cylinder bores. The bar is centered set to the desired depth of cut and the machine started. The cutter will bore progressively to the other end, and the machine stops when the boring complete. After the job is complete again the cylinder must be washed thoroughly to remove all abrasive particles.

Before starting reboring operation it is very important to prevent the entry of metal or abrasive particles in the oil galleries. It is a good practice to wrap insulation tapes on crank pins and to cover other parts as is possible.

Cylinder honing method

Honing the cylinder walls is necessary after re boring, or to remove minor imperfections and glaze. A hone consists of four or six narrow, fine-graded grinding stones mounted in cage around a spindle which is rotated by an electric motor.

In the fixed, machine-shop type hone, the cylinder block is mounted on the machine table, and the vertical or stroking movement of the hone up and down the bore often effected automatically. Portable hones, designed to be driven by a heavy duty electric drill mounted on a stroking stand are also widely used, especially in conjunction with a portable boring bar; in these cases the stroking action is effected manually.

Place the hone in the cylinder and expand the stones until the assembly can just be turned by hand and machine started. Home drive at drill speed while moving the hone up and down the entire length of the cylinder until the hone begins to run free. During this operation a liberal amount of kerosene, or other suitable cutting fluid, should be used to keep the stones clean.

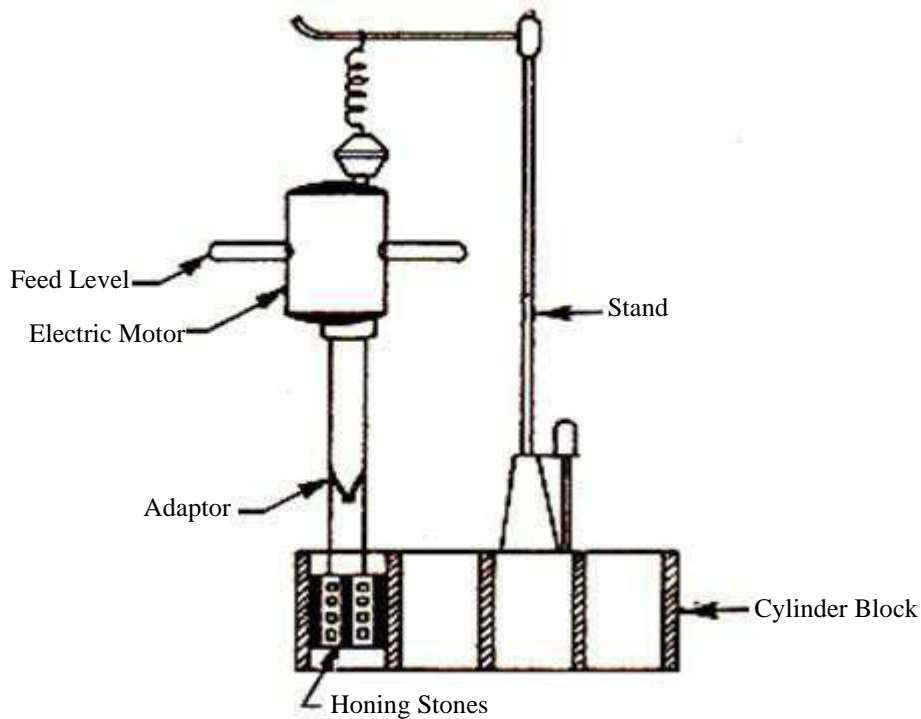

Fig 3.4 Cylinder Honing Machine

Move the hone up and down slowly with the first-cut rough rough stones, but more rapidly with the finish-cut line stones. Expand the stones against the cylinder walls and repeat honing operation until the desired bore diameter is obtained. After the honing is completed, all abrasive particles must be removed from the engine parts. Hot water and soap is recommended to clean the cylinder walls.

3.5 Valve seat cutting & valve grinding

The valve seats can be reconditioned with the help of valve seat grinders by 30 , 45 and 60 stone to get actual contact width. In absence of valve seat grinding machine valve seat cutters can also be used. Although the seats cut by valve seat cutters are not very good.

Operating procedure

1. Clean the seat carefully.
2. Fit 45 cutters to the holder and slide it into the valve guide.
3. Press down lightly on the handle and turn it right of left.
4. Do not grind the seat to much. Over grinding will reduce valve clearance.
5. If the outside diameter of the seating surface is too small, repeat the 45 grind until the diameter is within the specified range.
6. If the outside diameter of the seating is too large, make the 32 grind.
7. Grind the seat a 32 angle until the seat outside diameter is with in the specified range.
8. If the seat width is too narrow, repeat 45 grind until the seat is slightly too wide , and then return to the seat outside diameter.
9. If the seat width is too wide, make the 60 grind.
10. If the seat width is with in the specified range, lap the valve.

Valve seat grinding

The grinding stone of proper shape in rotated on the valve seat by means of concentric grinding .in this system the stone is kept concentric with the valve seat by a pilot installed in the valve guide.the pilots are usually adjustable enabling them to fit tightly in guides over a range of different sizes. Therefore,the use of pilot means that the valve guide must be serviced before the seat is ground. The stone is automatically lifted about once a revolution. this permits the stone to clear itself of dirt and dust by centrifugal force.

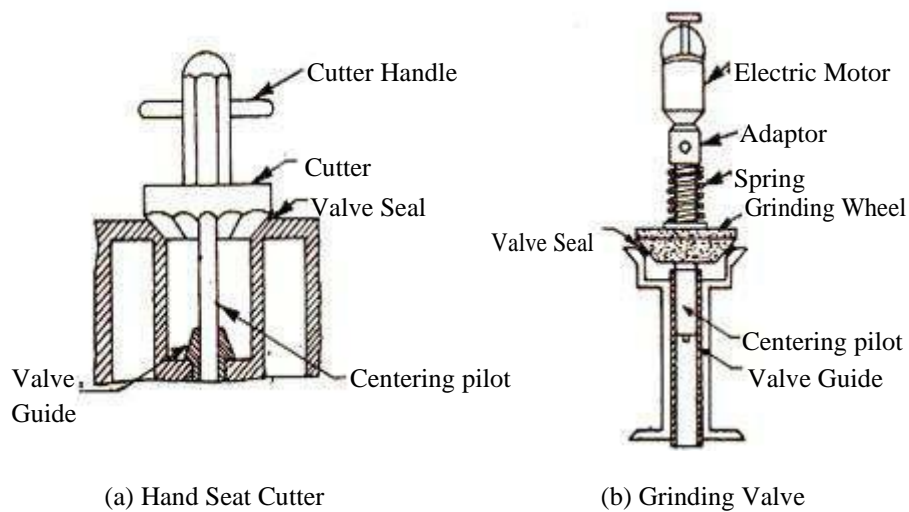

Fig 3.5 Valve Seat Cutting and Gridding

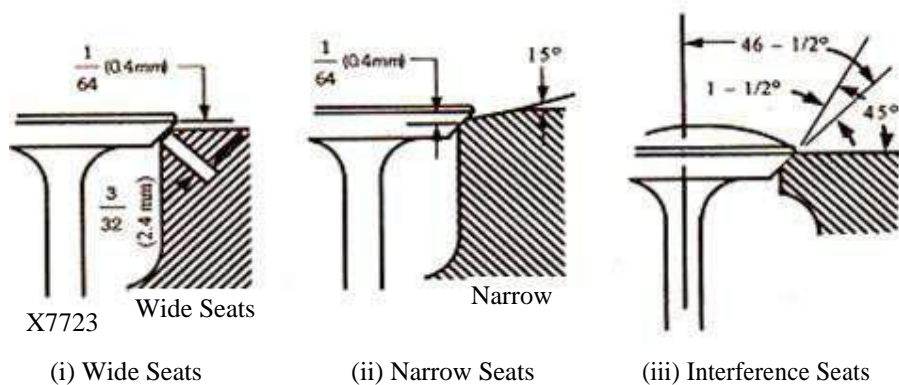

Fig 3.6 Valve Seats Grindings

3.6 Valve Refacing

If the valve face is badly scored or pitted, it may be done on a special valve refacing machine .

The machine consists of a grinding wheel operated by an electric motor. The valve is held in chuck which is also rotated with electric motor. There is a provision to set the valve chuck at any desired angle. This angle must just match the valve seat angle. Then put the valve into the chuck and tighten the chuck. The valve should be placed in the chuck so that the part of the stem that runs in the valve guide is gripped by the chuck.

To start the operation, align the coolant feed so that it sprays coolant on the rotating valve face. Then start the machine, move the lever to

carry the valve face across the grinding wheel. The first cut should be a light one. If this cut removes metal from only one half or one third of the face, the valve may not be centered in the chuck or the valve stem is bent, and the valve should be discard. Cuts after the first should remove only enough metal to true the surface and pits. Do not take heavy cuts. If so much metal must be removed that the margin is lost, discard the valve. Loss of the margin causes the valve to run hot. Then it will soon fail.

Before starting refacing operation, it must be ensured that the grinding wheel is properly dressed. This may be done on the machine itself, with the diamond dressing tool.

3.7 Crank shaft grinding

A special lathe or a crankshaft grinder is required to grind the journal and crank pins of a crankshaft. Crankshaft machine consists of a bed on which guide ways are provided, at one end head stock is mounted and another end tail stock is mounted. Both head stock and tail stock combinedly move on the bed ways along with crankshaft, a hand wheel is provided in front of machine for this purpose. The spindle can be driven by a separate motor.

At the back of the machine big grinding wheel is installed on a suitable base. It can be moved forward and backward by a hand wheel provided in front of the machine.

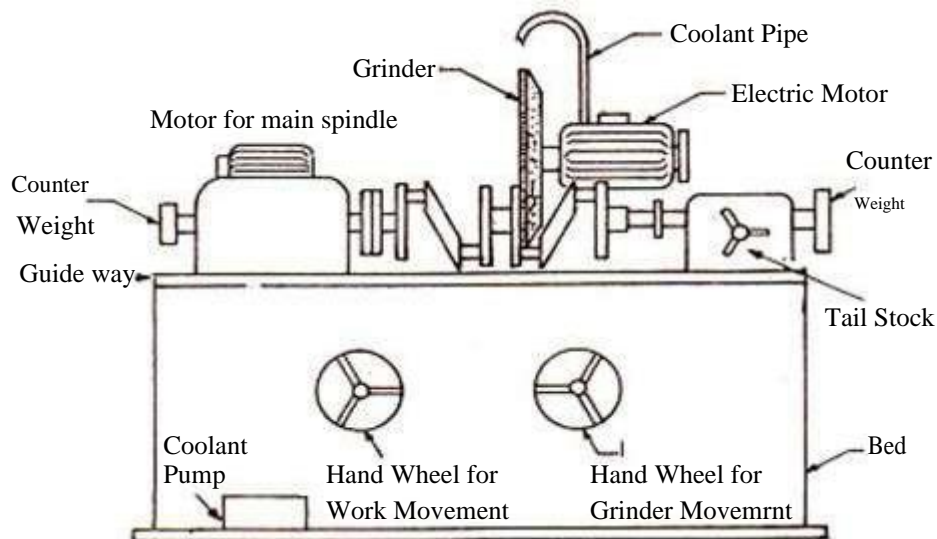

Fig 3.7 Crankshaft grinding machine

The grinding wheel is driven by a separate motor. A coolant pump is provided with a flexible pipe line to supply the coolant at the cutting zone. Counter weights are provided at head stock and tail stock to balance the crank shaft.

The crank shaft is mounted in between the chuck and the dead center. The job under process is centred each time with the spindle axis. Adjust the spindle speed and grinding wheel speed according to the specifications. Now start the machine and perform the grinding operation by bringing the grinding wheel against the work surface. A micrometer can be used to check diameter of crank pin and journal until required size is obtained.

Reconditioning of Brakes

4.0 Introduction

After prolonged use drums get worn-out and sometimes . when brake linings are wornout completely, the rivets rub against the brake drum and leave a lining marks. Usually four types of defects and wear takes place in brake drum. These are

- (a) Scored drum
- (b) Barrel shaped drum
- (c) Bell mouth drum and
- (d) Tapered shape drum

Under such circumstances these should be got turned on brake drum lathe before refitting. The operation of machining the brake drum friction surface produces an oversize diameter. To restore the break to peak efficiency will require that new brake shoe linings are installed which have oversize or extra thick linings corresponding to the new diameter of the drum. In market available standard sizes are given below.

First size – $1/32$ inches

Second size – $1/16$ inches

Last (or)third size – $1/8$ inches

Brake drum should be replaced when wear limit is reached.

4.1 Brake Drum Lathe

Drums are subjected to wear after prolonged usage, that brake drum must be turned for smooth and regular surface. Most of the drums can be turned out to 0.06 inches oversize and oversize lining is used.

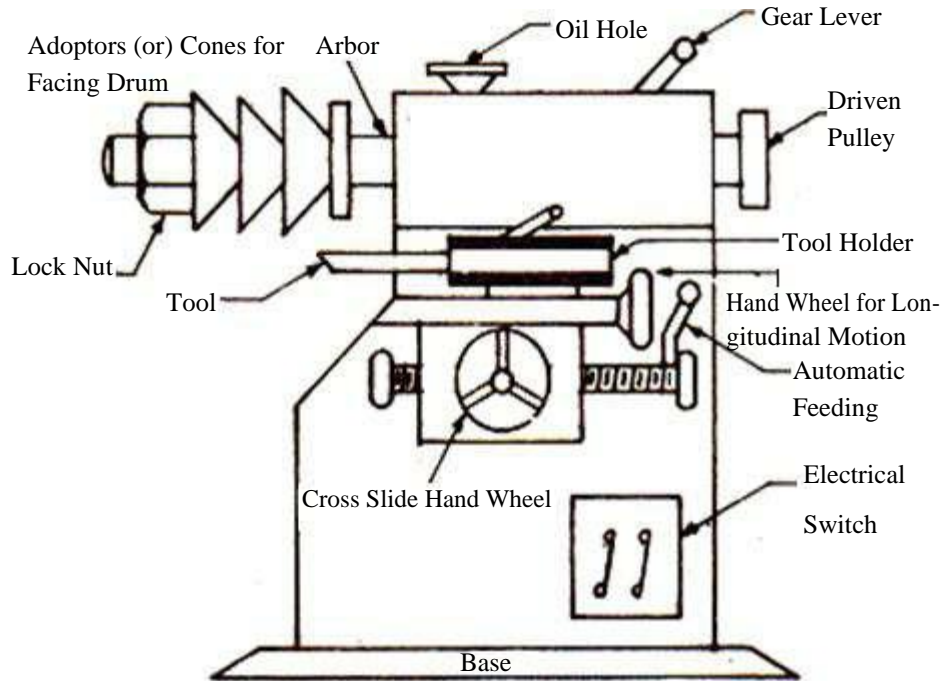

Fig 4.1 Break Drum Lathe Machine

The brake drum lathe machine is shown in fig 4.2. it consists of a base in which drive mechanism for the spindle or lathe arbor is arranges. One end of the

arbor has a radii adaptors or cones, which supports the different size of drums at bearing races in its hub. In front of the machine, there is a carriage on which toolbar is mounted. It holds the tool bits.

Two hand wheels are arranged to get longitudinal and cross slide motion for cutting tool. One automatic feed lever also arranged for the carriage movement.

The brake drum is mounted on the spindle and is locked with the help of the lock nut. Cutting tool is fixed in the tool post and set in the correct position. Now the machine is started and to check the mounting of the drum. Turn off the lathe and inspect the two scratches. If the two scratches cuts are not side by side the drum has been mounted improperly. Check the adaptors to make certain that the correct radii adaptors have been used or arbor locking nut is properly tight.

When the drum is correctly mounted, turn on the lathe and tool is given longitudinal movement to remove the metal on the surface of the drum. Depth of cut is adjusted with the help of cross feed hand wheel. The cutting operation is continued until the required diameter is obtained for the drum. The diameter can be check with the help of special drum micrometer. Care must be taken, that there should not be any excess removal of metal from the drum.

4.2 Brake shoe Riveting

After long usage the brake linings will get wornout. That the brake lining needs replacement, remove the brake shoes and drill out the rivets to remove old lining. Care should be taken that the drill of proper size is used, because a bigger size drill would make the holes wider and consequently make the re-riveting difficult.

For relining of brake shoe riveting machine is necessary which quickly rivet and to rivet without damage of the lining. the brake shoe riveting machine. It is provided with column on a base. The column houses the mechanism for operating the spindle. In front of the base a foot pedal is provided with a spring. Riveting rod is operated with the food pedal. In front of the machine there is knee over which the head is provided for placing the brake show. At the side of the machine grinding wheel is arranged for counter sinking of the brake shoe and for finishing the high spots of the brake shoe lining.

The brake shoe is placed on the head. Then operate the foot pedal, riveting rod is forced to move down ward hitting rivet, the riveting shank form a head. This process is repeated by bringing each rivet on the head. When ever riveting process is over the brake shoe is subjected to the grinding process to remove high spots on the brake shoe lining.

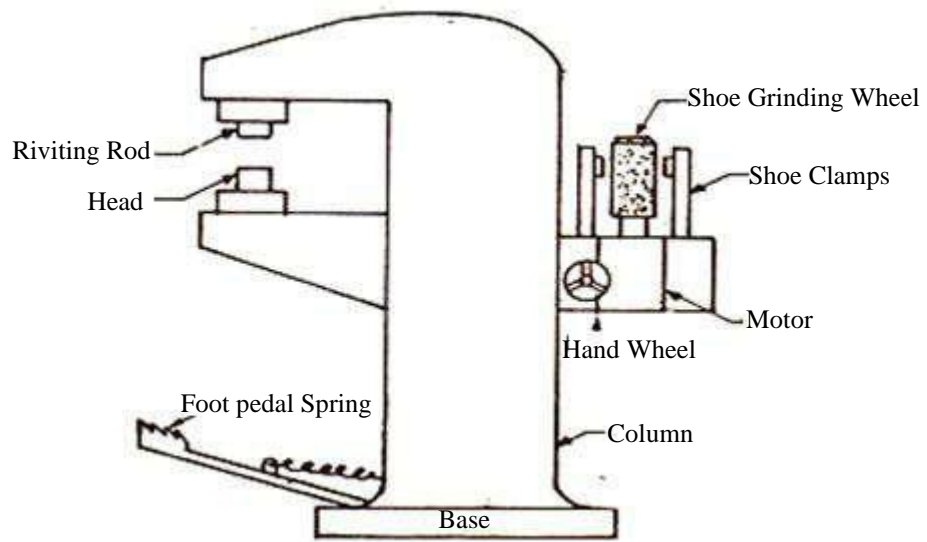

Fig 4.2 Brake Shoe Riveting Machine

Re-Conditioning Diesel Fuel Injection System

5.0 Introduction

While assembling a new injection pump or after long periods of service, it is necessary to check, test and calibrate the pump. These lists are performed by a skilled operator, with the help of a typical precision testing equipment. Three important tests must be carried out before refitting a pump to an engine. They are phase angle check test, calibration and governor test.

5.1 Fuel Injection Pump Test Bench (Phasing And Calibration Tests)

This bench is of two types

- (a) Hand operated and

(b) The motor driven.

On hand operated machine the pump is calibrated at limited speeds, thus also do not perform the governor test. Therefore the motor driven machine is very common to test the injection pumps now-a-days.

The motor driven bench consists of an electric motor of 2 to 3 h. p. Therefore the operating range of the pump can be obtained up to 4000rpm. This covers the full range of engine speed. The machine is mounted on a table, which has provisions to connect the pump at right alignments. A flexible coupling is provided to connect the shafts thus small error in alignment is eliminated. A trip plate is provided which trips-off at every 14seconds.

The delivery pipes from the pump are connected to the injection nozzles, the valves of which are spring loaded. The fuel delivered from the nozzle is measured by the glass vessels.

When the test to performed, the shaft is rotated at the testing speed, then the pump elements also deliver their fuel into a tray provided above elements also deliver their fuel into a tray provided above the measuring vessels. When complete air of the system is removed then the tray is quickly swung and the fuel is allowed to be delivered into the measuring vessels. This delivery of the fuel is allowed for 200 revolutions of the camshaft by the means of a counting device. After completing the above revolutions, the tray is automatically and quickly moved over to cover the tops of the measuring vessels.

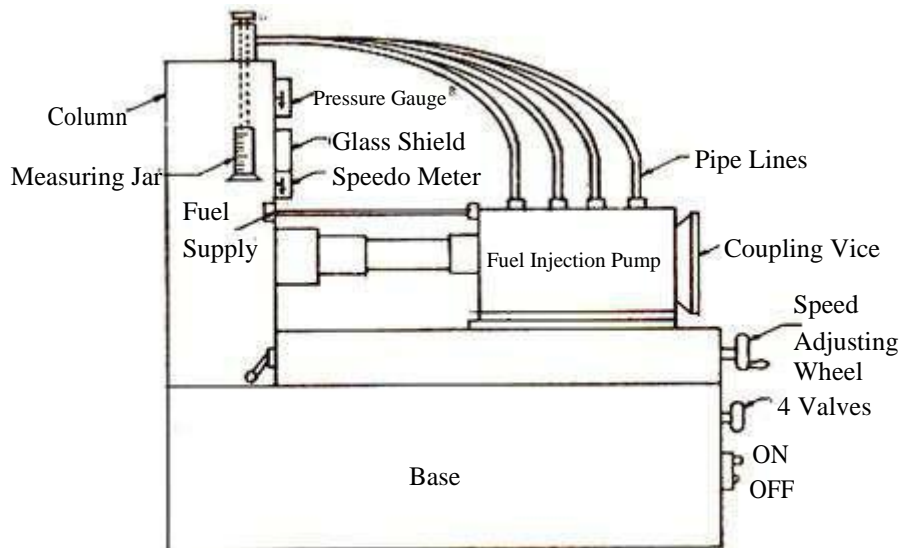

Fig 5.1 Fuel Injection Pump Test Bench

In this way the fuel delivered from the individual pump element can be read and compared from the measuring vessels. In this way the fuel delivered from the individual pump element can be read and compared from the measuring vessels. Finally pump is set and calibrated as specified by the manufactures.

Phase angle test

The object of this test to check interval between successive injections, so that for a six-cylinder pump the intervals will be 60 and for a four-cylinder pump 90.

1. The rack is set to a position stated by manufactures, using a pump rack setting device, the delivery valve and spring are removed from number one element and the test pipe connected to this element.

2. If necessary the tappet adjusting screw, tappet pads, or phasing shims should be altered to provide a small clearance, usually 0.6-1mm between the top face of the plunger and the base of the delivery valve seat. This is clearance may be measured with a dial gauge or by a special tool.

3. The pump camshaft is rotated by hand until number one element is at the bottom of its stoke, a valve on the test bench is opened to allow fuel to flow out of the test pipe, this is long spill.

4. Continued rotation of the camshaft will eventually cause the flow from the rest pipe to cease, indicating the point at which both inlet and spill ports are closed and delivery is about to commence, i.e., end of long spill.

5. The position of the camshaft when this occurs can be read from a pointer and 360 scale on the test machine.

6. This process should be repeated several times to verify the reading. Care must be taken not to confuse end of long spill and end of short spill. Which occurs when the plunger is moving down from T.D.C position?

7. Number one valve and spring should be replaced and the above procedure repeated in the firing sequence of the engine.

8. It is necessary the tappet adjusting screw, tappet pads, or phasing shims should be corrected until the timing of injection to each cylinder is within the prescribed tolerance typical value being $\pm 1/2$ of camshaft rotation. If adjustment has to be made, recheck the clearance of the plugers at the top of their respective strokes.

Calibration

Calibration of the pump should be carried after the phase angle test. This consists of adjusting each element to deliver an equal quantity of fuel to the cylinders. The quantity delivered per stroke depends upon the manufacturer's requirement. As the elements of the fuel pump deliver the fuel at various speeds and for different control – rod position. Fuel injection pump calibrated is as under.

1. Mount and couple the injection pump with the pump calibrating machine.
2. Set the control rod to the mid position or stay at 5mm rack position.
3. Make all the connections of fuel pipes at inlet and outlet of pump elements, ensuring them leak-proof.
4. Operate the machine and run the pump at 600 rpm and bleed the system by opening the air vent cock.
5. The trip plate is arranged in its position; allow the fuel to enter the glass tubes at 600 rpm and for 200 strokes. Then take the readings of fuel delivered into the glass tubes.
6. Compare these readings with the manufacturer's chart values for the 5mm rack position.
7. If there are variation in these readings then adjust the pump elements to bring the readings as close as possible to the given chart. This adjustment can be done by slacking the clamping screw and moving the control sleeve in desired direction and then again tightening the clamping screw. This adjustment should be corrected up to $\pm 2.5\%$ of fuel delivery.
8. Repeat the experiment at other speeds within the maximum range and check the collection of fuel at each speed. If there is any variation, the pump has to be serviced to put in normal working condition.

5.2 Fuel Injector Testing

With the help of injector tester, the injectors are tested for the following job characteristics

1. Pressure test
2. Leak-off test
3. Spray test.

1. Pressure test : To check the setting pressure, the pump is operated by the hand lever and the pressure at which fuel leaves the nozzle noted. In case the pressure is less, it is increased by loosening the check nut and tightening the adjusting screw and if it is more than specified, the adjusting screw is loosened. Typical values for setting pressures, which are slightly higher than working pressures, are 175 atmospheres for direct injection and 120-150 atmospheres for indirect injection.

2. Leak test : Fix up injector on tester, build up pressure of 150 atmospheres and keep the pressure for about 10 seconds (without spraying). After 10 seconds check up there is no drop in pressure and wetness is not felt on the tip of nozzle body. In case there is a drop of pressure in wetness is felt or droplet is seen of nozzle body, dismantle the injector, get the seat nozzle valve grounded and nozzle body seat lapped. In case nozzle valve seat is pitted it should be replaced or grounded. Fix up injector again and test in the same order.

3. Spray test : Inspect the spray pattern of the fuel; normally the spray should be uniform. If it is in stream form, the nozzle seat and valve seat should be grounded and checked once again. The spray sound is also checked good injector gives peculiar whistling sound. The spray angle is also checked during this test.

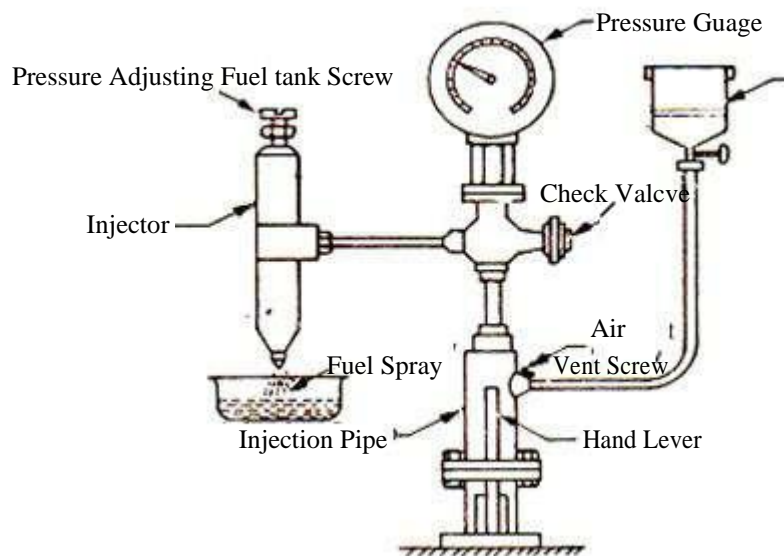

Fig 5.2 Fuel Injection Testing

Servicing And Maintenance

Structure

- 6.1 General procedure for servicing and maintenance of motor vehicles
- 6.2 Types of Maintenance
- 6.3 Types of Servicing
- 6.4 Maintenance and its role in trouble shooting of automobile

Learning Objectives

After the completion of this unit student will be able to

- To learn general procedures for servicing and maintenance of motorvehicles
- To understand about types of maintenance.
- To understand about types of servicing
- To know about automobile maintenance and its role in trouble shooting

6.1 General Procedure for Servicing and Maintenance of Motor Vehicles

Maintenance is an activity of utmost importance in the transport industry, for obtaining high standards and able to efficiently utilize, its operation and quality of services. Maintenance in general is the process of keeping a motor vehicle in good running condition . majority of automobile service nothing, but maintenance. In general it includes oil changes, chassis lubrication, tyre service,

engine tune ups, and servicing of transmission parts, brakes, springing system as well as wheel repair.

Different parts of an automobile usually fail or get out of adjustment due to long use. This long use and high speed running have greatly increased the necessity of maintenance and servicing of motor vehicles. By proper servicing, the vehicles become more comfortable, safer and easier to drive. Servicing in general is the process of either maintaining or restoring the vehicle to its original high state of perfection and performance. It is the sincere desire of establishing or maintaining of various original qualities of motor vehicle like appearance, performance, economy, safety, comfort and control. It is necessary to visit the service station as soon as a defect is found in the vehicle. If it is neglected, it is not desirable on a safety point of view. Hence the repair, whether it is major or minor, should be done immediately.

6.2 Types of Maintenance

There are four types of vehicle maintenance namely

1. Preventive maintenance
2. Brake maintenance
3. Periodic maintenance (or) schedule maintenance
4. Operation maintenance

1. Preventive maintenance : Prevention without breakdown or without giving trouble on road. Some attention or maintenance taken to the vehicle is called as preventive maintenance. It intends to reduce or totally eliminate breakdowns and accidents due to mechanical failures and reduces repair cost. Any good preventive maintenance program leads to following advantages.

- (a) Reduce the breakdown of vehicle
- (b) Increased safety due to reduced breakdown
- (c) Less expenses on repairs
- (d) Good control on inventory of spare parts
- (e) Lesser number of equipments are required

2. Break down maintenance : Break down maintenance is the attention which is to be provided when a motor vehicle becomes immobilized due to faults created during running. These faults are started difficulties, puncture,

electrical faults, carburetors and fuel supply faults, overheating, fan beltings, breakage and accidents etc.

3. Periodic maintenance : Periodic maintenance or operative maintenance is the attention provided to motor vehicle after in operation for a specified time or covered distance. These maintenance may be done daily , weekly, quarterly, yearly or after covering every 500km, 1000km, 2000km, 4000km, 8000km, of running. In garages this work is done on the basis of pre-set schedules so as to avoid road failures and to minimize break down during use.

4. Operation maintenance : Daily maintenance by the operator for proper running of the vehicle is known as operation maintenance. It is needed to keep the vehicle in proper working condition. Tire inflation, battery, brakes, clutch, smoke color, starting system, ignition system and lights are checked in this maintenance daily.

6.3 Types of Servicing

Type of servicing

The servicing of a motor vehicle is of following types

1. Cleaning of the motor vehicle and its parts
2. Inspection and repair of different parts
3. Adjustments
4. Greasing and lubrications

Cleaning of the motor vehicle and its components:

A layer of oil, grease and dirt gets coated to the motor vehicle and its parts with passage of time and usage. Before performing servicing of the vehicle (i.e., disassembly, inspection and repair), the unwanted layer should remove. This can be done by hand cleaning or by means of certain cleaning methods, hand cleaning which seems to be quite cheap and easy is the most expensive process.

The cleaner equipment selected the method application used greatly influence the speed, thoroughness and economy of the cleaning operation. Most commonly used methods of cleaning automobiles and its parts are steam cleaning, water pressure cleaning, solution cleaning and vapour bath cleaning. To clean engine of dirt, grease etc., spray method with compressed air should be used. For this purpose a kerosene spray under pressure is sprayed on engine.

For cleaning engine exhaust system (exhaust manifold, pipe and the muffler), take them apart and soak them in kerosene oil overnight. A pack of kerosene soaked waste attached to a long wire may be drawn through it for cleaning the pipe and the manifold.

Decarburizing engine parts

It is the operation of removing carbon deposits on cylinder, exhaust port, piston ring grooves, combustion chamber in the cylinder head and piston crown.

Remove the cylinder head, for scraping the carbon deposits from the piston crown, cylinder block and cylinder head by means of its scraper if the special equipments not available. Around the periphery of the piston crown, a ring of carbon should be left. Around the top of the cylinder bore, the rim of the carbon should not be touched. For resting it on the top.

Now remove the carbon deposits from the valve stems valve parts and combustion space of the cylinder head by means of compressed air or with the help of a tyre pump followed by through cleaning the paraffin.

Greasing of motor vehicle

Greasing of a motor vehicle involves seven main components

1. Engine lubrication
2. Chassis lubrication
3. Rear axle and differential lubrication
4. Transmission lubrication
5. Universal lubrication
6. Steering mechanism lubrication
7. Lubrication of springs

There are two methods of lubrication of the chassis

- (i) Low pressure grease cups
- (ii) High pressure grease compressors.

In the first method, low pressure grease cups are screwed down by hand to force the grease into bearings. In the other method known as high pressure

system, a power compressor is used to force the lubricant into the bearing under pressure.

6.4 Maintenance and its role in trouble shooting of automobile

The routine maintenance, the day to day adjustments and minor repairs required by all vehicles and major overhaul of a 2 wheeler are quite different although each of them is to keep the vehicle in good working order. No piece of machinery will continue to work indefinitely without attention. If maintenance is neglected entirely, the machine may go on functioning for quite a long period, but eventually a serious defect will develop and need skilled attention to put it right, which means a costly repair bill. The best way of preventing troubles is the constant and methodical inspection. A task system requiring a daily or weekly check on each aspect of mechanical side should be adopted.

Fault finding should be methodical and systematic. An engine will work properly if the correct charge of air-fuel mixture is being induced into the crank case transferred to cylinder, properly compressed, fired at the right moment, and the residue properly exhausted except in case of a mechanical failure.

Advantages of good maintenance

1. Reduces the breakdown of vehicle
2. Increased safety due to reduced breakdown
3. Less expenses on repairs
4. Increase the life of vehicle
5. Good control on inventory of spare parts
6. To obtain the maximum, performance.

Servicing and Maintenance of Two Wheelers

7.1 Maintenance Schedule of two Wheelers

For peak performance and high pitch efficiency of the following schedule should be followed.

Daily maintenance

With daily inspection, the following checks are also recommended before going on a long drive.

- (a) Check fuel level, if necessary, refill carefully.
- (b) Clean the vehicle completely, wash if necessary the body, seat, dash board, fuel tank and wheels etc.,
- (c) Check tire pressure when tire is cold.

- (d) Check operation of all lights, horn and switches.
- (e) Check the clutch and brake lever cables and free play.
- (f) Check the wheel nuts.

Weekly maintenance

Every week check the two wheeler properly. If the vehicle is not checked weekly, it will breakdown in running. So, the following parts should be checked.

- (a) All the daily schedules should be followed with the following
- (b) Servicing of vehicle or water cleaning.
- (c) Check the oil level of gear box and if necessary top up
- (d) Tighten the shock absorbers bolts and nuts
- (e) Adjust the brakes
- (f) Lubricate the chassis points and wash the chain with kerosene and relubricate it with grease
- (g) Tighten chassis bolts, handle steering bolts etc.
- (h) Check the ignition system (i.e., spark plug, C,B points and HT coil)
- (i) Clean the air cleaner
- (j) Adjust the belt or chain tension.

Monthly maintenance

After 2,000 kms of driving or every month if the monthly mileage is less than this figure, the following additional items require attention.

- (a) Check the oil level in the gear box and if necessary top up
- (b) Check the clutch and adjust it
- (c) Check the brake and adjust it
- (d) Check the pick up of engine
- (e) Check the spark plug electrodes gap, if necessary adjust
- (f) Check the condition of belt, replace if it worn out
- (g) Lubricate all the parts like cable ends, rear suspension lever, clutch and brake levers, handle bar bottom bearing, wheel bearing etc,
- (h) Carburetor should be dismantled and cleaned out thoroughly

(i) All easily accessible nuts and bolts may be tightened

General and periodic check up

After the first 500 to 750 kms: warm the engine and drain off all oil through the drain hole provided. Pour some fresh oil and run the engine for a few seconds.

Every 1000 kms: check oil level in the gearbox by unscrewing from the crank case the level screw marked 'OIL'.

Every 6000 kms

1. Remove the air cleaner from the carburetor and agitate in a 30% oil-petrol bath.
2. Change oil in the gear box.
3. Clean the spark plug and adjust the gap to 0.6mm. Inspect the spark plug electrode colour. If the engine operating correctly and properly, the colour at the insulator tip will be grayish yellow to light brown. If the air fuel mixture too rich; the colour at the insulator top will be dull black, velvet.
4. Check steering column adjustment.
5. Check handle bar fixing clamp.
6. Clean the silencer exhaust pipe and decarbonizes the engine.
7. Lubricate the speedometer drive pinion and flex drive.
8. Grease all joints on the brake controls.
9. Check and adjust front and rear brake.
10. Check and inflate tire.
11. Check front and rear shock absorber.
12. Check and adjust ignition timing (for C.B. point)

Every vehicle 9000 kms

1. Repeat operation at 4000 km level.
2. Decarburizing the engine, silencer.
3. Check exhausts emission level.

Every vehicle 12000 kms

1. Repeat operation at 4000 km level.
2. Lubricate front wheel bearing and hub pins.
3. Overhauling of front fork.
4. Overhauling of carburetor.
5. Decarbonising of engine.

Servicing

1. Engine oil level check: check engine oil level each day before operating the motor cycle. The oil filter cap is on the right crank case cover and contains a dipstick for measuring oil level.
2. Oil change: change engine oil with the engine warm and the motorcycle on its main stand.
 - (i) To drain the oil, remove the dipstick and drain plug.
 - (ii) After the oil has completely drained, make sure that the sealing washer is in good condition and reinstall the drain plug.
 - (iii) Fill the crank case through the dipstick opening with 0.75 liters of the recommended SAE 20W 40 (SF/SG grade) grade oil.
 - (iv) Reinstall the dipstick.
 - (v) Start the engine allow it to idle for few minutes.
 - (vi) Stop the engine.
 - (vii) Make sure that oil level is at the upper level mark.

3. Clean oil filter screen

- (i) Drain the engine oil thoroughly.
- (ii) Remove the kick starter pedal, muffler, disconnect the clutch cable and rider foot rest.
- (iii) Remove the filter screen and wash it in clean petrol.
- (iv) Reinstall the filter screen, right crankcase cover, rider foot rest, muffler and kick starter pedal.
- (v) Fill the crankcase with clean engine oil.

-

After the first 500 to 750 kms.

- (i) Inspect the fuel line.
- (ii) Inspect and adjust the throttle operation.
- (iii) Clean and adjust the carburetor.
- (iv) Clean the air cleaner.
- (v) Inspect and clean air cleaner.
- (vi) Check and adjust the valve clearance.
- (vii) Change the engine oil.
- (viii) Clean the centrifugal oil filter and screen.
- (ix) Check, clean, lubricate and adjust the drive chain.
- (x) Check the battery specific gravity.
- (xi) Check and adjust brake shoe wear.
- (xii) Check headlight, clutch and front suspension.

Every 2500-2800 km

- (i) Repeat 500-750 km check, exception of oil filter and oil pump cleaning.
- (ii) Over hauling brake system

Every 5000-550 km

- (i) Repeat operation at 500-570 km level.
- (ii) Check fork oil level.
- (iii) Check battery electrolyte.

Every 7000-7500km

- (i) Repeat 500-570 kms check.
- (ii) Check front and rear brake shoes.
- (iii) Change front fork oil.
- (iv) Check steering head bearing adjustment.
- (v) Check steering lock – action.

7.2 Adjustment Control of Motor Cycle (2wheeler)

1. Idle speed adjustment: do not attempt to compensate for faults in other systems by adjusting idle speed.

The engine must be warm for accurate idle adjustment. Ten minutes of stop and go-riding is sufficient.

Warm up the engine and rest the motor cycle on the main stand.

Adjust idle speed with the throttle top screw. Idle speed.

2. Throttle adjustment: check for smooth rotation of the throttle grip from the fully open to the fully closed position. If the cable is kinked, chafed or improperly routed, it should be replaced or rerouted. Standard throttle grip play is approximately 2-6mm of grip rotation. For free play adjustments loosen the lock nut and turn the adjuster.

3. Valve clearance adjustment: excessive valve clearance will cause noise, and little or no clearance will prevent the valve from closing and cause valve damage and power loss. Check valve clearance at the specified intervals.

The checking or adjusting of valve clearance should be performed when the engine is cold. The clearance will change as the engine temperature rises.

(i) Remove the magneto cover and two tappet covers.

(ii) Rotate the flywheel anti-clock wise and align the 'T' mark with index mark. Make sure the piston is at the top of the compression stroke by moving the rocker arms with your fingers. If they are free, piston is at the top of the compression stroke. If they are tight, rotate the flywheel 360 and re align the marks.

(iii) Check the clearance by inserting the feeler gauge between the adjusting screw and valve stem.

(iv) Standard clearance for inlet and exhaust valves 0.05 mm. if adjustment is necessary, loosen the lock nut and turning the adjusting screw until there is a slight drag on the feeler gauge. After tightening the lock nut recheck the clearance.

(v) Install all parts in the reverse order of disassembly.

4. Drive chain adjustment: the service life of the drive chain is dependent upon proper lubrication and adjustment. Poor maintenance can cause premature wear or damage to the drive chain and sprockets. Under severe usage, or when the motor cycle is ridden in unusually dusty areas, more frequent maintenance will be necessary.

-

Inspection

(i) Turn the engine off, place the motorcycle on its main stand and shift the transmission into neutral remove whole cap.

(ii) Drive chain slack should be adjusted to allow approximately 20-30mm vertical movement by hand. Roll the motorcycle and check drive chain slack as the wheel rotates. Drive chain slack should remain constant as the wheel rotates. If the chain is slack in one section and in another, some links are linked and kinked and binding. Binding can frequently be eliminated by lubrication.

(iii) Inspect the sprocket teeth for wear or damage.

(iv) If the drive chain or sprockets are excessively worn or damaged, they should be replaced. Never use a new chain with worn out sprockets since this will result in rapid chain wear.

Adjustment

(i) Remove the split pin and loosen the rear axle nut.

(ii) Loosen the sleeve nut, turn the adjusting nut on both the right and left chain adjusters to increase or decrease chain slack. Align the chain adjuster index marks with corresponding scale graduations on both sides of the swing arm.

(iii) Tighten the rear axle and sleeve nut.

(iv) Recheck drive chain slack.

(v) If rear brake pedal free play is affected when repositioning the rear wheel to adjust drive chain slack. Check rear brake pedal free play and adjust as necessary.

(vi) Lubricate the chain by applying liberal amount of SAE-90 oil or chain lubricant.

Front brake adjustment

(i) Measure the distance the front brake lever moves before the brake starts to take hold. Free play should be 10-20mm at the tip of the brake lever.

(ii) Make free play adjustment by turning the adjusting at the front brake arm. Make sure the cut-out on the adjusting nut is seated on the brake arm pin after making final free play adjustment.

(iii) Apply the brake and check free wheel rotation when released.

Rear brake adjustment

(i) Place the motor cycle on its main stand.

(ii) Measure the brake pedal free play before the brake starts to take hold. Free play should be 20-30 mm.

(iii) If adjustment is necessary, turn the rear brake adjusting nut. Make sure that the cut out on the adjusting nut is sealed on the brake arm pin after the final adjustment has been made.

(iv) Apply the brake several times and check for free wheel rotation when released.

Clutch adjustment

Clutch adjustment must be required if the motorcycle stalls when shifting into gear or tends to creep or if the clutch slips, causing acceleration to lag behind engine speed. Normal clutch lever free play is 10-20mm at the lever

(i) To adjust the free play, loosen the lock nut. Turn the adjusting nut to obtain the specified free play. Tighten the lock nut and check the adjustment.

(ii) Start the engine, pull in the clutch lever and shift into gear. Make sure the engine does not stall, and the motor cycle does not creep. Gradually release the clutch lever and open the throttle. The motorcycle should start smoothly and accelerate.

Trouble Shooting of 2 Wheelers

S.NO	Trouble	Remedy
(i)	Engine does not start or is hard	
1.	To start No fuel is getting to the carburetor	Inspect fuel in the tank; refill the fuel tank if necessary and clean the fuel line if clogged
2.	Air filter choked	Clean the air filter
3.	Air suction valve	Check and ensure for proper tube connection
4.	Ignition system	Make sure that the ignition switch is 'ON' and HT wire is connected

5.	Try spark test	Remove the spark plug and connect the spark plug high tension wire. Touch the side electrode of spark plug to the engine. Check if sparking takes place at spark plug gap by operating kick starter
6.	If no sparking	Inspect for loose contacts at wire terminals of CDI unit
(ii)	Engine starts but stalls	Ensure the choke lever is in 'fully open' position and fuel valve is open.

(iii)	Poor pick-up	
1.	Air filter clogged	Clean the air filter
2.	Spark plug loose in cylinder head	Tighten the spark plug securely
3.	Clutch slipping	Adjust the lever free play
4.	Brake binding	Adjust the brake lever (or. Pedal free play
5.	Too low tire pressure	Correct tire pressure
(iv) Excessive fuel consumption		
1.	Fuel leakage	Inspect fuel lines
2.	Air filter clogged	Clean the air filter
3.	Worn out spark plug electrodes	Reduce the spark plug electrodes
4.	Too low tire pressure	Correct tire pressure
5.	Faculty carburetor	Service the carburetor
6.	Improper valve timing	Adjust the valve timing
7.	Poor compression	Worn out piston rings, piston, cylinder and valves

(v) Engine over heating		
1.	Firing incorrect	Adjust spark plug gap
2.	incorrect spark plug heat range	Use correct specification of spark plug
3.	Air cleaner poorly sealed	Clean the air cleaner
4.	Oil pump adjustment in correct	Adjust properly
5.	Compressor high	Clean the carbon inside the cylinder
6.	Carbon built lap in exhaust port	Clean the exhaust port
(vi)		
1.	Petrol is too low an octane rating	Use correct octane rating fuel
2.	Piston, rings or bore badly worn	Replace
(vii)		
1.	Weakened springs	Replace the springs
2.	Worn clutch plates	Replace the clutch plates
(viii)		
1.	Gear change drum dowel broken, select fork broken	Replace them
2.	Selector fork bent or worn	Repair or adjust
3.	Gears seized on shaft	Service them
4.	Defective change lever	Replace
(ix)	Steering pulling (or wobbling)	
1.	Tire pressure less	Inflate the tires
2.	Bearing races to tight (or pitted)	Service (or replace it)

3.	Unbalanced shock absorbers	Repair them
4.	Defective swing arm	Repair (or replace)
5.	Loose/missing spokes	Properly tight (or fit the spokes)
6.	Tire defective	Replace the tire
7.	Deformed rim	Repair (or replace it)
(x)	Poor braking	
1.	Brake adjuster not proper	Repair it
2.	Glazed or greasy lining	Roughen the surface of lining
3.	Excessive worn-out/run out brake drum	Replace the brake drum
4.	Water in the drums	Clean and dry
5.	Operating cam worn	Replace it
(xi)	Abnormal noise from engine	
1.	Excessive valve tappet clearance	Adjust the velvet clearance
2.	Worn tappets	Replace
3.	Worn piston rings and small end of connecting rod	Replace them
4.	Excess carbon in the head	Remove the carbon
5.	Worn or damaged main bearings	Replace them
6.	Defective chain or sprockets	Repair or replace them
(xii)	Feeble horn sound	Inspect the battery
(xiii)	No light	Inspect the fuse or bulbs or light replace the fuse or bulbs

Servicing And Maintenance of 3 Wheelers

Structure

- 8.0 Introduction
- 8.1 General And Periodical Maintenance of 3 Wheelers
- 8.2 Adjustment, Dismantling, Assembling and Trouble Shooting of 3 Wheelers

Learning Objectives

After the completion of this unit student will be able to

- Periodic and schedule maintenance of 3-wheelers
- Dismantling, assembling and trouble shooting of three wheeler

8.0 Introduction

The automobile 3 wheelers are usually used as passenger vehicles and also as cargo vehicles particularly in the urban areas. By using the 3 wheelers, the time will be saved and also the transport only 2- stroke petrol engines were used in 3 wheelers. But now a days 4- stroke both petrol and diesel engines are also used in 3 wheelers.



Fig 8.1 Three Wheeler (Bajaj Auto)

8.1 General And Periodical Maintenance of 3 Wheelers

(a) Periodic Maintenance

1. Wash and clean the vehicle.
2. Replace gear box oil.
3. Replace differential oil.
4. Clean air filter element.
5. Replace air filter element, 'O' ring of air filter cover.
6. Clean spark plug. Adjust electrode gap.
7. Inspect fuel system.
8. Clean oil filter.
9. Clean the carburetor. Adjust CO% and HC
10. Inspect and replace if necessary engine breathe pipe.
11. Gear shifter sector greasing.
12. Inspect engine compression pressure.
13. Drive shaft greasing.

14. Inspect front & rear brakes for effective working / bleed the system, if required / check leakages and brake fluid level.
15. Tighten all important nut, bolts, fasteners like engine foundation, cylinder head, trailing arm, silencer mounting, shock absorber etc.
16. Front suspension greasing.
17. Inspect and adjust fork assembly.
18. Inspect and adjust all control cables.
19. Rear axle bearing greasing.
20. Clutch lever lubrication.
21. Brake pedal linkages oiling.
- 22) Inspect and correct front & rear tyre pressure.
- 23). Tyre rotation – To enhance the life of tyre, rotate the tyre as indicated. The best tyres should always be kept at rear side. Inspect tyre thread wear and replace tyre if necessary.
24. Check and adjust free play.
25. Inspect battery terminal voltage, sp. gravity and electrolyte level.
26. Inspect rear brake switch / reverse light switch / all electrical for proper working.
27. Leak test of CNG / LPG at joints.
28. Gas filters element cleaning.
29. All rubber components in gas kit replacement.
30. Gas cylinder testing.

(b) Schedule Maintenance

Gear box oil

Gear box oil level checking procedure

1. Park the vehicle on level surface to check the oil level.
2. Remove the oil level plug.
3. The oil level is correct, if oil just starts flowing out when the plug is removed.

-
4. If oil is not flowing out i.e. less oil level top up with specified oil till the oil starts flowing out. Fit back level plug.

Gear box oil replacement

Replace oil as per lubrication chart.

For replacing gear box oil

1. Run the engine for about 10 minutes to warm up the oil.
2. Place the vehicle on a level ground so that the oil settles down.
3. Remove oil drain plug. Let the oil drain completely.
4. Tighten the drain plug.
5. Remove breather pipe and pour the correct quantity of recommended oil.
6. Check the oil level.
7. Fit back breather pipe & clip properly. Ensure that there is no oil leakage.

Differential oil

Differential oil level checking procedure

1. Place the vehicle on a level ground.
2. Let the oil settle for a few minutes.
3. Oil level can be measured by means of dip stick.
4. Remove the dip stick carefully.
5. Wipe off the dip stick clean.
6. Re-insert the dip stick fully (screw in fully) and take out to note the oil level.
7. In case the oil level is below the lower mark, top it up to the upper mark.

Differential oil replacement

Replace oil as per lubrication chart.

For replacing engine oil

1. Run the engine about 10 minutes to warm up the oil.

2. Place the vehicle on a level ground so that the oil settles down.
3. Remove oil drain plug. Let the oil drain completely.
4. Tighten the drain plug.
5. Remove dipstick and pour the correct quantity of recommended oil.
6. Check the oil level.
7. Fit back dipstick. Ensure that there is no oil leakage.

Air filters cleaning

1. Clean with kerosene and squeeze.
2. Clean with kerosene again and blow low pressure compressed air.
3. Dip into engine oil. Squeeze and remove excess oil and dry with lint free cotton cloth.

Lubrication

Replace the oil in accordance with periodic maintenance chart.

	Recommended oil grade	Quantity
Engine oil	SAE 20W40 of API 'SG' + JASO'MA' grade	800ml
Differential oil	SAE 20W40 of API 'SG' + JASO'MA' grade	250ml
2T oil	Bajaj genuine oil – HPCL make	1.4 litre

Spark Plug

1. Clean any dirt from around spark plug base.
2. Remove spark plug by using plug spanner provided in the tool kit.
3. Adjust the gap if incorrect by bending outer electrode carefully.

Spark plug gap : 0.5 to 0.6mm

Spark plug : WR4AC

Spark plug cap : Resistive

Tyre pressure

Keep appropriate tyre pressure as mentioned below to increase life of the tyre and for better fuel consumption.

-

Universal Joint Propeller Shaft:

Universal joints and slip joint on each propeller shaft are provided. Greasing has to be done as per recommended procedure.

Changing wheel and tyres

Pull the parking brake and unloose the wheel

8.2 Adjustment, Dismantling, Assembling and Trouble Shooting of 3 Wheelers

(a) Engine tuning procedures

Petrol mode idle setting

1. Preset the carburetor air screw to 1 ¼ turns out from full closed condition.
2. Warm up the engine by running vehicle on the road.
3. Set idle speed with the help of idle screw on the carburetor.

Gas mode power setting

1. Generally this is factory set and is not supposed to be disturbed. In case if adjustment is required, follow the sequence below.
2. Ensure no petrol in carburetor. If required run the vehicle in neutral fuel mode with choke on to consume petrol in carburetor.
3. Preset the power screw such that its top face is deep from the power valve body face.
4. Start the engine in gas mode and adjust the idle screw on regulator such that the specified idle speed, is achieved with minimum opening.
5. Push the power screw in. With engine neutral, open the throttle to confirm that engine does not rev up above 6000rpm.
6. Now gradually start opening the power screw out just till the point at which specified engine speed can be achieved with engine rev up.
7. The final power screw setting is ¼ turn further out from sr.6 above.

Gas mode idle settings

1. Allow the engine to idle in warmed up condition.
2. Rev up the engine with flick of throttle for 2-3 times.

3. Adjust the idle screw on regulator such that the specified idle speed is achieved with minimum opening.
4. Repeat stage 3 and confirm the repeatability of idle speed.

(b) Removal of engine from chassis

1. Disconnect battery connections.
2. Disconnect HT cable connection to spark plug.
3. Disconnect HT coil coupler.
4. Loosen and remove the nuts fitting silencer to block. Then loosen and remove the bolts mounting silencer to chassis.
5. Remove pipe connection of air suction valve.
6. Take out silencer.
7. Remove oil filter wire clip by loosening and removing long head bolt.
8. Disconnect 2T oil pipe connection from oil pump.
9. Disconnect oil pump cable from lever.
10. Disconnect reverse switch coupler.
11. Disconnect electrical connections to starter motor.
12. Remove clutch cable adjuster and disconnect cable from lever.
13. Disconnect stator plate couplers.
14. Disconnect engine earth connection from engine.

(c) Engine dismantling

1. Remove spark plug.
2. Remove wood ruff key crankshaft.
3. Remove gear shifter gasket.
4. Remove 4 nos cylinder head mounting flange nuts with spring washer and plain washer.
5. Pull out cylinder head. Take care 2 nos dowels while removing cylinder head.
6. Remove cylinder head gasket.

7. Pull out cylinder block. Take care 2 nos dowels while removing cylinder head.
8. Remove oil pump gasket.
9. Remove clutch cable bracket mounting flange nut. Remove bracket.
10. Remove clutch spring seating plate.
11. Take out steel washer for clutch nut.
12. Lift and remove inlet manifold carefully from studs to avoid damage to inlet manifold.
13. Remove reed valve gasket.
14. Remove crankcase gasket.
15. Remove main shaft oil seal from the differential side.
16. Disconnect battery connections.
17. Disconnect HT cable connection to spark plug.
18. Disconnect HT coil coupler.
19. Remove HT Coil from crankcase by loosening 2 screws.
20. Remove cylinder head cowling by loosening one screw.
21. Loosen and remove the nuts fitting silencer to block. Then loosen and remove the bolts mounting silencer to chassis.
22. Remove pipe connection of air suction valve.
23. Take out silencer.

Assembly Of Engine

1. Load the crankcase clutch side on engine supportable.
2. Guide the MG pin along with the cluster gear through the groove and align the same with the hole in crankcase clutch side.
3. Lightly tap the other end of the MG pin. Ensure that the 21 rollers are properly greased & in place.
4. Fit lock plate and finger tight the nut. Holding other end of the MG pin with spanner.
5. Assemble the crankshaft assembly on crankcase clutch side. Please avoid damaged to oil seal while fitting.

6. Assemble the main shaft assembly in crankcase clutch side. Lightly tap the main shaft while rotating to properly engage the speed gears with multiple gear.
7. Check for easy rotation of all speed gears with cluster gear and easy to and for movement of stem.
8. Assemble starter gear on cluster gear assembly.
9. Apply grease on main shaft and cluster gear end.
10. Fit washer on main shaft to fit between the main shaft and ball bearing face.
11. Clean the mating surface of the crankcase halves and apply liquid gasket.
12. Recommended liquid gasket three bond.

(d) Fuel system

Carburettor

1. Clean carburetor at every 10000kms.
2. Check / adjust idling RPM as per specification.
3. Check / adjust conical needle clip position as per specification.
4. Check / adjust air screw as per applicable model.

Compression Checking

Check compression pressure at every 20000 kms.

Do's

1. Use appropriate screw drivers.
2. For cleaning always use carburetor cleaning like
 - Acetone
 - Carbon tetra chloride
 - Aerosol
 - CVC spray
3. Float is in good condition.
4. Float pin

-

- Tip having no wear mark.
- Spring loaded pin is free in movement 5. Needle jet
- No wear at taper portion.
- Circlip position is in specified groove. 6. Piston valve
- No wear mark.
- Diaphragm condition.

Don'ts

1. Never use over size screw drivers.
2. Do not over tighten the jets and screws.
3. These will damage the jets and their seats.
4. Never clean the carburetor with water.
5. Jets & air passages will get clogged due to sediments if cleaned by water.
6. Replace

Jets

- Worn out jet.
- Incorrect size jet.
- Punctured, squeezed and distorted float.
- Worn out tip.
- If spring loaded pin is sticky.
- Needle worn out at taper portion.
- Piston valve worn out. Scoring marks

(e) Lubrication system

1. Ensure proper seating of pump mounting surface on the crankcase / mounting member.

2. Good quality gasket shall be used between pump and the crankcase / mounting member.
3. Apply uniform tightening torque for both the mounting screws.
4. Pump mounting member should be very rigid. Overhanging member or loosely fitted member may lead to undue vibration during running.
5. Maintain close clearance fit between pump body spigot and mounting bore.
6. Ensure free rotation of pump drive shaft after tightening the mounting screws.
7. Ensure there is no additional / extra thrust force to the pump drive shaft. Always keep positive clearance between drive shaft and driven member on all sides.
8. Ensure initial setting of oil pump throttle position i.e. check whether two marks in the pump body and lever plate are aligned.
9. Always use throttle cable to supply require oil to the respective engine speeds.
10. Always use good quality of 2T oil available in sealed pack / container.
11. Oil filter in a oil tank is must. Ensure that it is cleaned during every filling.
12. Use of oil indicator mechanism is recommended for ensuring oil in the oil tank.
13. Bleed screw position must always be on the top side after mounting the pump.
14. If the oil tank is totally empty, priming / bleeding processes needs to be redone.

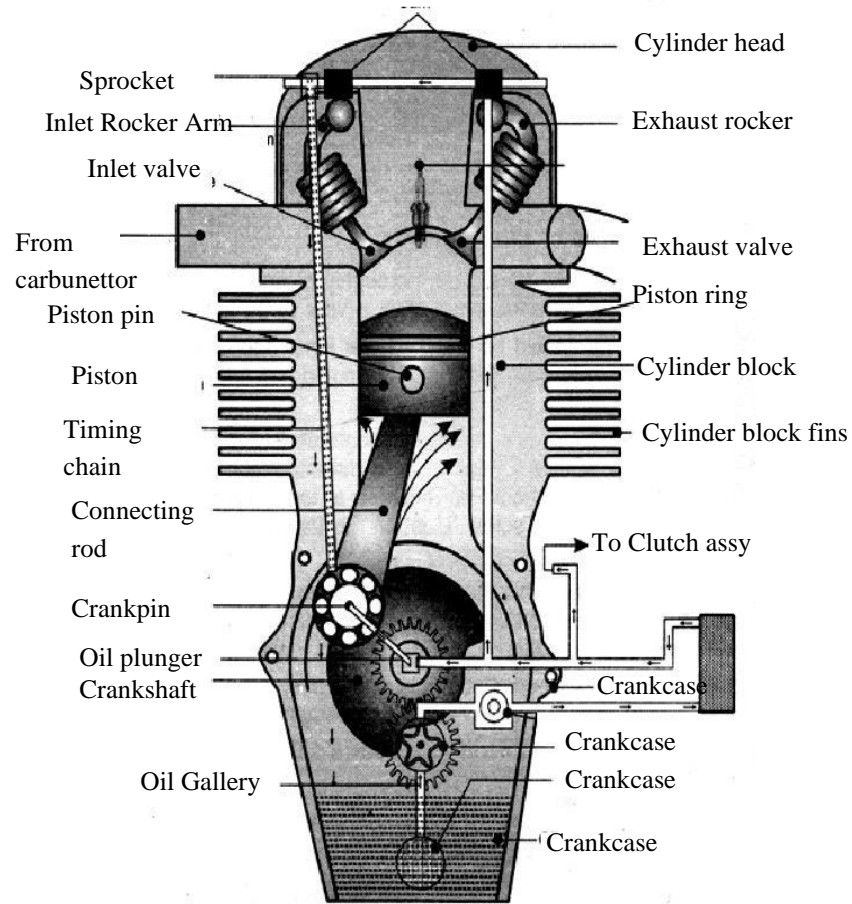

Fig 8.2 lubrication system

(f) Steering suspension system

Dismantling And Assembling

1. Put the vehicle on jack/stand.

Remove

1. Bolt (10mm), which secures lock clip of front axle nut, from both the sides.
2. Lock clip.
3. Both sides' coller type nuts of front axle.
4. Front wheel from the links along with axle.

5. Special nut from the axle.
6. Take out axle.
7. Remove the pipe and bolt when come from TMC.
8. Front brake drum nuts.
9. Take out the brake drum.
10. Oil seal from both sides of brake drum.
11. Circlips from both the sides.
12. Bearing from the front brake drum.
13. Front brake drum plate & keep it properly supported to avoid damage to hydraulic brake hose.

Steering System Maintenance

1. Clean and lubricate both ball bearings with grease at every 10000 kms
2. Check & adjust steering column vertical play by adjusting lock ring with the help of special tool.
3. Replace steering column bearings if any sideways play is noticed in steering column.
4. Handle bar lock bolt should be tightened as per specified torque. Steering may fail in case this bolt is kept loose.
5. Check for any bend or damages to steering column as this may lead to directional instability.
6. Do not increase the maximum travel of steering from lock to lock positions.

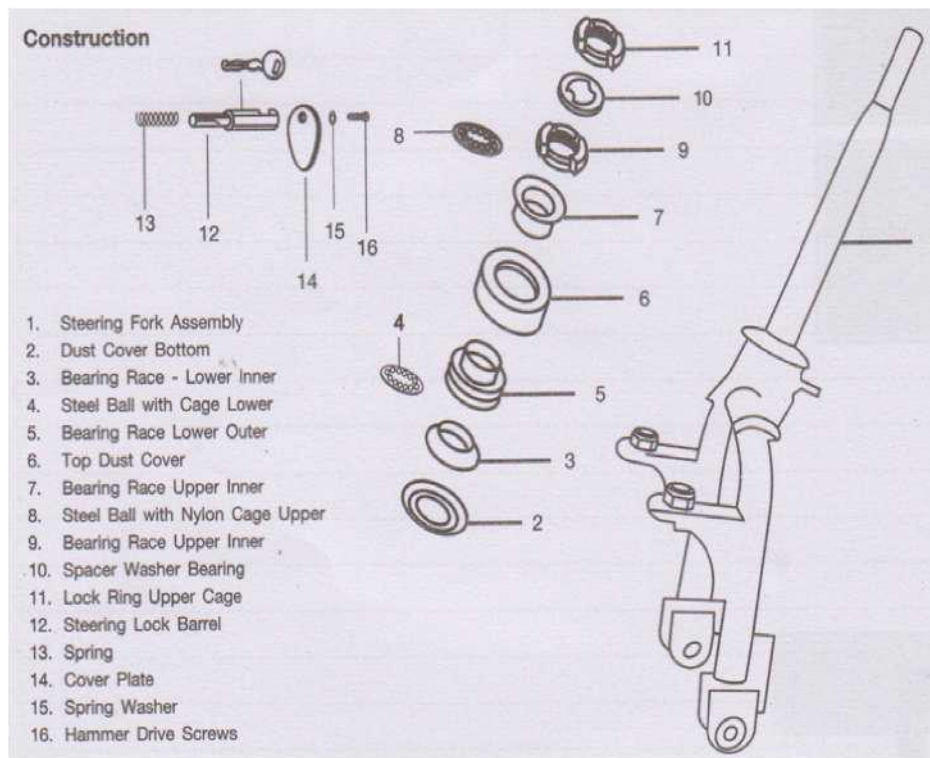

Fig 8.3 steering

(g) Rear suspension

Rear suspension dismantling and assembling

1. Put the vehicle on jack/stand.
2. 3 nuts of rear wheel rim.
3. Rear wheel.
4. Rear brake drum circlip lock by using plier.
5. Rear brake drum.
6. Propeller shaft bolts & nuts from flange yoke.
7. 4 nos bolts & nuts.
8. 'S' type lock of axle nut.
9. Remove axle nut.
10. Rear wheel axle by gently tapping from another end.

11. Parking brake inner cable from drum plate.
12. Disconnect the hydraulic brake pipes banjo bolt from the drum plate.

Removal Of Brake Disc Assembly

1. Remove the 4 bolts of drum plate and separate the brake disc assembly from trailing arm.

Removal Of Rear Suspension

1. Remove rear shock absorber mounting bolt & nut from lower end pivot pin of trailing arm.
2. Remove the suspension nut from the upper half of the rear shock absorber.
3. Always make sure that the lower bolt of shock absorber is attached to pivot pin, to avoid consequential damaged to shock absorber assembly.

Removal Of Trailing Arm

1. Trailing arm pivot pin nut by using spanner.
2. Push pivot pin partially out.
3. Tap the trailing arm bolt and pullout the trailing arm bolt from the other side.
4. Safely remove the trailing arm assembly.

(h) Brake system

Dismantling Of The Tandem Master Cylinder

Unscrew and Remove

1. Reservoir mounting bolts.
2. Hold the brake fluid reservoir and by rocking it on both sides, lift the same out of the rubber grommets fitted on to the TMC ports.

Remove

1. Rubber grommet from the TMC inlet ports.
2. Piston stops screw, copper gasket and the Circlip by slightly depressing the primary piston.

- 3. Primary piston
- 4. Secondary piston

Dismantling of tandem master cylinder

- 1. Primary spring. Spring retainer, seal & the seal shim from the primary plunger.
- 2. Secondary spring, seal retainer, pressure seal, seal shim from the front end of the secondary piston.

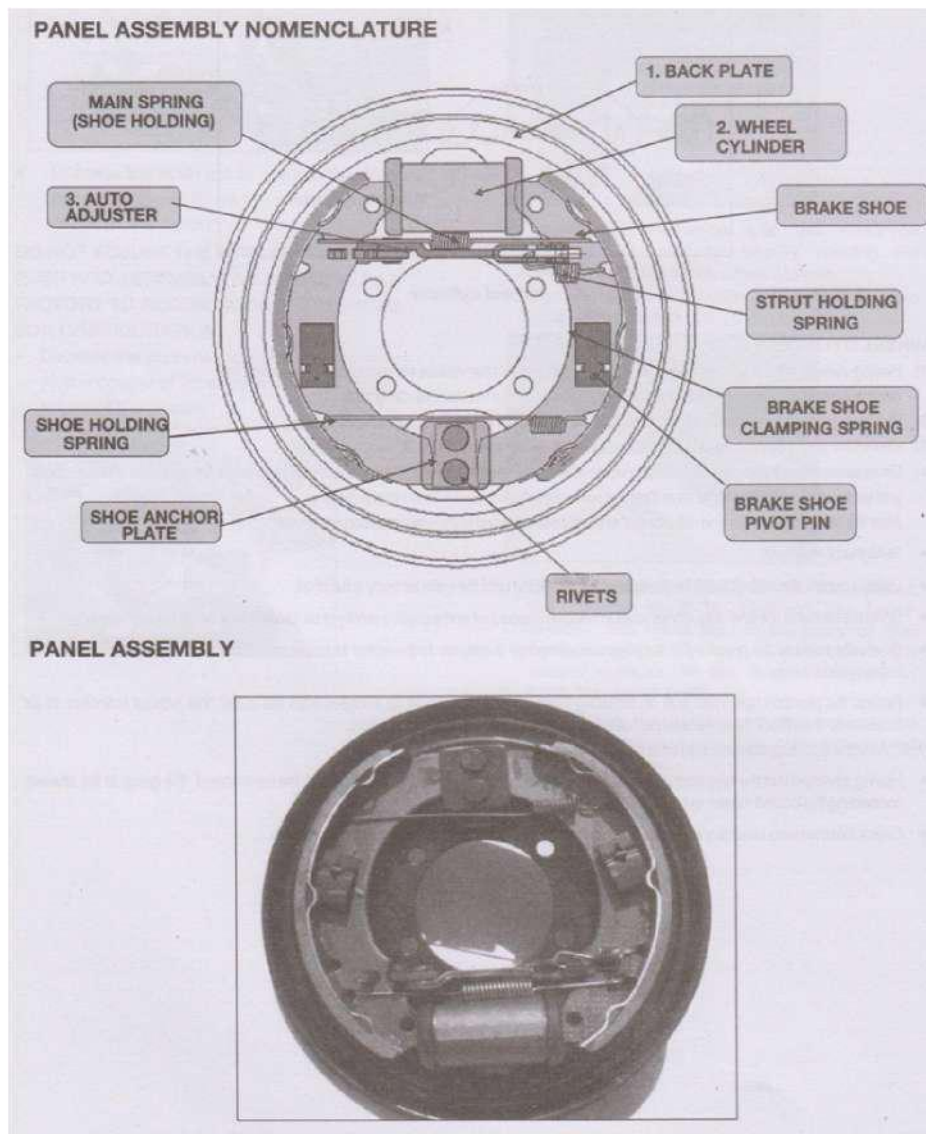

Fig 8.4 Brake System

(i) Maintenance-electrical

Battery : As you aware that, periodic maintenance and care of battery helps to enhance its life.

(a) Checking Of Battery On New Vehicle In Pdi

1. Check the battery open circuit voltage.
2. If battery voltage in received condition is less than 12v; inform the details in attached format to warranty dept. preserve the record at your end to send it to warranty dept. along with warranty claim in case battery failure has taken place during warranty for manufacturing defect.
3. If battery manufacturing date is more than 2 months old for dry charged batteries and 1 month old for charged batteries, inform it to warranty dept. in format given in annexure-1 if any of these batteries failed within warranty claim them under warranty to BAL along with this report as well as battery checking report from Exide dealer.
4. Charge the battery externally and put on vehicle.
5. Ensure that battery cables are fixed firmly and petroleum jelly is applied to battery terminals.

(b) Dry Charged Battery Charging Procedure:

1. Remove the short plastic plug on the exhaust vent outlet and replace it with the long open tube provided with battery.
2. Do not crimp or bend the exhaust tube. This is a safety device to remove fumes. Blockage of this tube may cause damage to the battery.
3. Fill each cell with dilute sulphuric acid of 1.240 specific gravity.
4. Keep the battery as it is for half an hour.
5. Keep vent plugs open. Connect battery to charger and charge at proper current as indicated below.
6. Charge continuously as given below.

Sr. No.	Battery Type	Charging time required
1	12V9Ah	10-15 hours
2	12V50Ah	24-30hours

-
7. After the battery charging is over, charge indicator LED will lit.
 8. The terminal voltage with battery connected to charger, when measured with multi meter should show voltage between 14.5 to 15.2 v, when the battery is fully charged.
 9. Stop charging when charging is over. For a fully charged battery, open circuit voltage should be greater than 12.3 V, measured after one hour of charging.
 10. Specific gravity of individual cells, should be > 1.22 when measured after one hour of charging.

(c) Checking the specific gravity

The charged condition of the individual cell can be checked by measuring specific gravity of electrolyte in that cell. The specific gravity of electrolyte can be checked by using hydrometer having small diameter spout.

For measuring the specific gravity bring the electrolyte in the hydrometer to eye level and read the graduations on float scale bordering on the lower meniscus.

(d) Battery installation

- (a) Ensure that in all cells the level of electrolyte is near the maximum level mark.
- (b) To clean & dry the surface, wipe the top of the battery with a clean cloth. Fasten the battery firmly with bracket and allied fasteners.
- (c) Connect cables to the positive and negative terminals properly. Reverse connections will damage the charging system permanently.
- (d) Always connect the “negative terminal last”.
- (e) Clean the battery terminals and cable connections. Smear them with petroleum jelly to avoid corrosion.

(e) Care In Use Battery

1. Always keep the battery dry and clean.
2. Visually inspect the surface of the battery container. If there are any signs of cracking or electrolyte leakage from battery, replace the battery.
3. The electrolyte level in all the cells should be checked after every 45 days and topped up, if necessary with distilled water only. Never use acid or ordinary tap water for topping up, since it will shorten the battery life.

(f) Battery sulphation

1. Under charging.
2. Standing in a partially or completely discharged condition for long time.
3. Low electrolyte level if electrolyte level is permitted to fall below the top of the battery plates, then the exposed surfaces will harden and becomes sulphated.
4. Adding acid if acid is added to a cell in which sulphation exists, the condition will be aggravated.
5. High specific gravity if specific gravity is higher than the recommended value(1.240) then sulphation may occur.
6. High temperature accelerates sulphation, of an idle, partially discharged battery.

(g) Non-Use Maintenance

1. Remove the battery from the vehicle.
2. Maintain electrolyte level 1/4th above the plates.
3. During off service period, battery should be charged once a month.
4. Keep the battery fully charged.
5. Store the battery in cool, dry place.
6. Keep the battery away from rain, moisture and direct sunlight.

(h) Trouble Shooting

Starting trouble

(a) No / less supply of CNG

1. CNG cylinder.
2. Solenoid valve not working.
3. Presence of petrol in carburetor.
4. Defective selector switch.
5. Supply line.

-

(b) HPR mal functioning

1. Piston ball
2. Piston movement sticky
3. Internal leakage through 'O' rings
4. Non genuine springs
5. Mixer malfunctioning

(c) LPR malfunction

1. Power screw tampered.
2. LPR filter.
3. Idling screw tampered.
4. Diaphragm spring not working properly.
5. Oil accumulation in LPR.
6. Idling screw spring not working properly.
7. Torn diaphragm.

Poor pickup / poor acceleration

(a) Less supply of CNG

1. CNG cylinder
 - (i) Gas pressure lower than 50 bar.
 - (ii) Manual shut off valve not opened fully.
 - (iii) Presence of petrol in carburetor.
2. Supply lines
 - (i) Mixer malfunctioning.
 - (ii) Supply hose kinked.

(b) HPR malfunction

1. Piston movement sticky
 - (i) Oil entry in HPR.
 - (ii) Breathing hole blocked.

2. Piston spring not ok

(i) Spring rate reduced.

(ii) Not genuine.

(c) LPR malfunction

1. Power screw tampered.

2. Idling screw tampered.

3. Diaphragm spring not working properly.

4. Oil accumulation in LPR.

5. LPR breather holes choked.

(d) Smoky exhaust

1. Oil supplied with CNG.

2. Oil accumulation in LPR.

3. Oil accumulation cylinder.

4. CNG filling station compressor oil throw.

Servicing and Maintenance of 4 Wheelers

9.0 Introduction

To keep the motor vehicle in a condition of safety, reliability, comfort, cleanliness, performance and economy, automobile service is very necessary in the modern fast moving time. The automobile service includes many diversified servicing operations transmission service as well as testing and repair of automobile engine and electrical equipment.

Before servicing an automobile, it is necessary to determine the cause of the trouble in the automobile. This is done by observing the symptoms produced by the trouble and indicated in the instrument checks, visual examination, sounds. The analysis of troubles and troubleshooting charts are very helpful for this purpose. In an automobile trouble are liable to occur in all the systems like fuel. Lubrication, cooling, ignition, breaking as well as in engine power train.

Overhauling

In the workshop practice the activities carried out basically of two types as under

1. Maintenance
2. Overhauling

1. Maintenance : The maintenance activities include the adjustments and replacements of subassemblies with regards to kilometers, or stipulated time. The maintenance type also known as periodic service includes the replacement of components are also termed as fast moving items like various kinds of oils, grease, rubber parts, brake shoes, filters etc.

2. Overhauling : It is the process of ensuring efficient operation of an automobile. It includes internal cleaning, replacement of worn-out parts and adjustment of other parts to ensure its efficient operation.

Necessity of overhauling : The over hauling of each system can be considered with the diagnosis of a doctor. The doctor treat the patient initially

with the help of medicines in first phase. If the disease continue to a happen he verify it through paramedical system, such that X-ray, scanning, ultrasound etc.

After identifying the defective organ he start the operation. Similarly the process of overhauling includes the pre-checks and its initial counter measures to rectify the defect. If the defect still persist then he had to overhaul the system and defective organ to be replaced. The provision in automotive system is also given where the standard component it can't be installed then oversize or undersize

component can be used. In all systems of automobile the scope is there that insist of replacing major assembly only few components are changed.

Although there is no such time or kilometer is fixed that at this particular instants the system is overhauled. The overhauling needs more dependent upon the operating conditions. For example in some cases engine requires overhauling even before 50,000 kms and in some cases the life of engine is more than 2.3 lakhs of kms. The driving habit also effects the overhauling.

Overhauling procedure : The overhauling of any assembly of is major activity which consists of the steps as follows.

- (i) **Evaluation :** Whether overhauling is required or not.
 - (ii) **Pre-checks :** To decide to locate the defect at initial stages
 - (iii) **Dismantling :** It is to be done in perfect order as per instructions given by the manufacturer the numbering and proper keeping of components.
 - (iv) **Inspection :** The inspection condition of each component is also checked at the time of dismantling.
 - (v) **Cleaning :** By each component is thoroughly cleaned by cleaning agents and dried.
 - (vi) **Replacements :** The defective components are removed and in place of these components which are having correct dimension are placed.
 - (vii) **Assembly :** The assembly of the component is done in accordance to the guideline provided by the manufacturer. The correct positioning is also checked at each stage.
-

9.1 Engine

To avoid total breakdown of the engine, its interior should be cleared periodically, parts checked for wear and the repairs and adjustments should be carried out, if necessary. In general, engine overhaul is of two types.

1. Top overhaul: it is also known as partial overhaul. Top overhaul is carried out in the following operations.

(i) Removing the cylinder head, valves and piston and clean the carbon on these parts. After cleaning of parts check the condition of parts to wear, damage or scratches. If any part is defective replace it with new one.

(ii) After checking of parts, oil the all parts thoroughly.

(iii) Make sure that the valves are in their original valve guides.

- (iv) In case cylinder head gasket is in good condition, fit it before refitting the cylinder head by tightening all the nuts by finger tight. Then starting at the centre of head tighten the nuts in sequence order.
- (v) Refit parts removed from the cylinder head one by one.
- (vi) As per recommendations of the engine makers, the valve clearance may be adjusted.
- (vii) For good efficiency and longer life of the engine the engine oil should be changed.

Major overhaul : For carrying out the major overhaul as explained below.

- (i) Remove the radiator connection hoses, battery terminator accelerator linkages.
- (ii) Remove the air cleaner and carburetor.
- (iii) The nuts and bolts holding the propeller shaft to the gear box as well as the engine bearer bolts may be removed.
- (iv) Now remove the engine assembly from the vehicle and keep it on a prepared stand.

Disassembling of engine : Engine disassembly is carried out in a sequence as follows.

- (i) Remove the water pump; exhaust manifold, oil filter, thermostat, crankshaft pulley, oil pump and timing gears.
- (ii) Remove cylinder head.
- (iii) Remove oil pan.
- (iv) Remove piston and connecting rod assembly (give the numbers on pistons and connecting rods for easy reassembling).
- (v) Remove flywheel and crankshaft.

Cleaning and inspection : After dismantling all the parts, clean and inspect them carefully, replace the defective parts.

- (i) All parts should be cleaned with kerosene and dry them with the compressed air.

- (ii) The cylinder walls may be inspected for scoring. The cylinder may require reboring or re honing if scores are present.
- (iii) To inspect piston for scores, remove the ring without breaking them. In case of deep scores, replace the piston. While light scores may be polished off. Measure the clearance between the sides of the piston in the cylinder. In case they are scored. Replace them.
- (iv) Inspect the piston ring for damage or wear. If these are defective, replace them.
- (v) Inspect the connecting rod small end and big end bearings. If these all scored or pitted. Service with the rebutting.
- (vi) Check the valve face and seat. If any part is defective service the valve face with the valve refacing and cut the valve seat for correct setting of valves.

Reassembling of engine parts : All parts are reassembling with respective place and adjust the accelerator linkage and fuel supply. Then refit the engine on vehicle.

Definition of tune up : Tune-up is the process of making checks and minor adjustments to improve the operation of the engine.

Tune : Up is also preventive maintenance. Troubles can be caught early and prevented by checking out the engine before it actually fails.

Tune-up procedure

The tune-up procedure restores drivability, power, performance and economy that have been lost through wear, corrosion and deterioration of engine parts. These changes take place gradually in many parts during normal car operation. A typical tuning procedure is given below.

Air intake and exhaust system

- (i) Clean out pre cleaner
- (ii) Remove and clean air cleaner
- (iii) Swab out inlet pipe in air cleaner body
- (iv) Inspect exhaust system and muffler
- (v) Check crankcase ventilating system for restrictions.

Basic engine

- (i) Recheck air intake for restrictions.

-
- (ii) Check radiator for air bubbles or oil indicating compression or oil leaks.
 - (iii) Cylinder head gasket leakage
 - (iv) Retighten cylinder head cap screws
 - (v) Adjust valve clearance
 - (vi) Check compression pressure in each cylinder.
-

9.2 Fuel system

1. Check fuel lines for leaks or restrictions.
 2. Clean fuel pump sediments bowl
 3. Test fuel pump pressure
 4. Clean and check carburetor
 5. Service diesel fuel filters
 6. Check diesel injection pump
 7. Check and clean injector
 8. Bleed diesel fuel system
 9. Check diesel injection pump timing
-

9.3 Lubrication System

1. Check operation of pressure gauge or light
 2. Service oil filter.
 3. Check condition of crankcase oil
 4. Check engine oil pressure
-

9.4 Cooling System

1. Check water pump for leaks and excessive shaft and play
2. Inspect radiator hoses
3. Clean and flush cooling system
4. Test thermostat and pressure cap
5. Check condition of fan belt

9.5 Transmission system

Clutch Overhaul

A general procedure for clutch overhaul has been explained the following procedure.

Removing the clutch : The exact procedure to be followed for removing the clutch depends upon the particular make of the car and the instruction manual for the same must be consulted however the general procedure may be outlined as follows.

- (i) Remove the gearbox from the chassis including various clutch and gearbox linkages.
- (ii) The clutch assembly is separated from the engine by removing the flywheel screws.

Disassembling

(i) Before starting dismantling the clutch cover assembly, it is very important to mark the relative positions of various components so that they can be reassembled easily.

(ii) Place the cover assembly under a press, with wooden blocks and apply pressure by hand to cover and remove the three adjusting nuts. Release the pressure gradually till the clutch springs are completely free.

(iii) Lift off the cover to inspect various parts inside.

(iv) If it is required to remove the other components.

Cleaning & inspection

(i) Now clean the dismantled parts of the clutch with kerosene.

(ii) Inspect the clutch facing for wear. In case it is worn-out up to the rivets heads, replace with new one.

(iii) Inspect the cushioning and torsion springs on the clutch plate. In case they are found to be cracked or weak, complete plate has to be replaced.

(iv) Check the pressure springs for stiffness. If variation in case of a particular spring from the original value is more than the allowable, the same should be replaced.

(v) Clean and grease the thrown out bearing. Now hold the inner race and try to rotate the outer race keeping it under pressure. If the rotation is not uniform the bearing needs replacement.

(vi) Check the pressure plate; it should have a smooth plane surface. In case it is distorted by more than 0.3mm, or is badly scored, replace it.

Assembly

- (i) Grease various clutch components requiring lubrication before reassembling.
- (ii) Place the pressure plate on the blocks placed over the press bed and place pressure springs on it at suitable places.
- (iii) Fit also the release levers and place the cover over the assemble parts.
- (iv) Apply pressure gradually taking care that the bolts are guided properly through the holes in the cover.
- (v) Then tighten the nuts in proper order and with the correct maximum torque. Remove the pressure by releasing press.

Refitting clutch

- (i) Attach the clutch cover assembly to the fly wheel by means of bolts, placing the clutch plate in between the fly wheel and correct assembly.
- (ii) Make sure that the clutch plate is centralized. This may be done by using a clutch alignment bar.
- (iii) Refit the clutch operating linkages and lubricate to the linkages.

Clutch adjustment

Although the clutch is fitted and set very accurately on the initial assembly of the vehicle, however it requires some adjustments. Usually following adjustments are made on most of the clutches :

(i) Free pedal play adjustment: this adjustment is required to keep a specified amount of free play in the pedal after the clutch has been engaged. This adjustment is made by changing the length of one rod located somewhere in the clutch linkage. It should be made only after the correct floor board clearance or clutch pedal travel has been made. If no free play is kept is May result is noise and damage to release bearing and also slipping of clutch. In light vehicles, it is kept between 15mm to 25mm, in heavy vehicle; it is kept between 30 to 35mm.

(ii) Clutch release lever adjustment: this adjustment should be made every time the clutch is removed from the vehicle. By making this adjustment to manufacturer's specification, a clutch rebuilding machine equipped with a dial gauge or a gauge plate is used.

9.6 Ignition system (s.i. engines)

- (i) Clean, test and adjust spark plugs
- (ii) Test ignition coil and check for proper coil connections
- (iii) Check the distributor cap and rotor
- (iv) Check the condenser, C.B. points
- (v) Check the ignition timing

9.7 Steering, brakes and suspension system

Servicing of brakes

Each make and model of automobile may require certain specific procedures for the maintenance and adjustment of the hydraulic system. When such adjustment or maintenance is necessary, the manufacturer's services manual should be referred to for the proper procedure.

Any complaint of faulty braking action should be analyzed to determine the cause. Brake service includes addition of brake fluid, bleeding the hydraulic system, repair or replacement of master cylinder, replacement of brake linings and over hauling of wheel cylinder.

Servicing of Brake Shoe Assembly

The procedure of servicing of brake shoe assembly is as follows

1. Raise the vehicle so that all the four wheels are free.
2. Remove the wheels, hubs and drums which will give access to the brake shoes.
3. The brake shoe retaining spring is removed by using brake shoe spring phase.
4. Remove the brake shoe pivot pin and washer.
5. Brake shoes are removed after twisting a locking wire around the wheel cylinder to retain the pistons in position.
6. The complete unit of wheel cylinder is removed.
7. Examine the back plate for any defect.
8. The brake drum is examined for wear and scored and it has to be turned on a brake drum lathe if necessary.
9. Examine the brake shoe lining for wear and damage.

10. Install the brake shoe assembly and adjust for proper working.

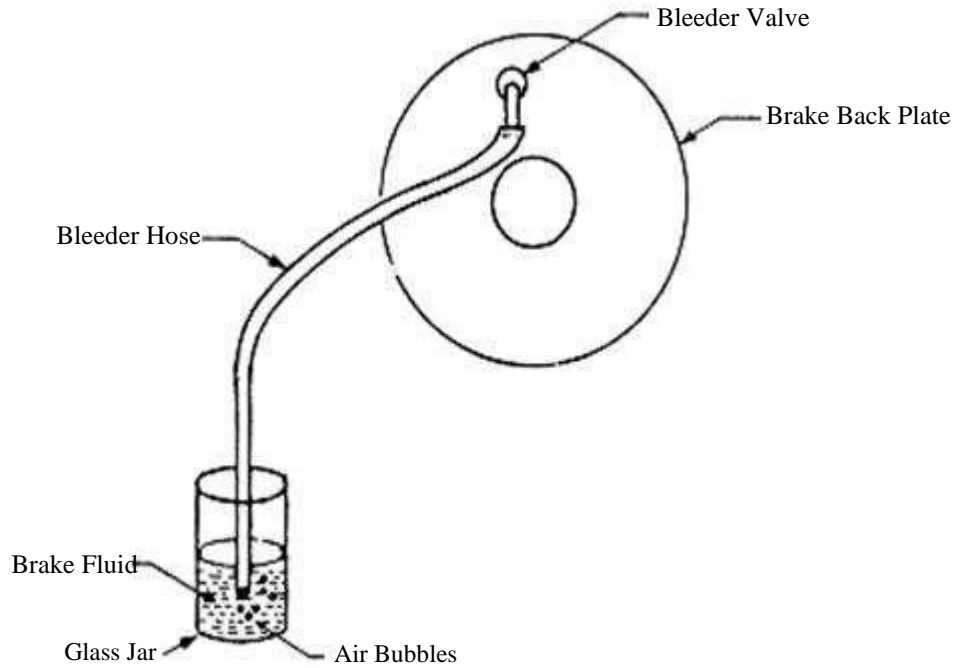

Fig 9.1 Bleeding of Brake

Overhauling of Master Cylinder

Servicing of master cylinder is proceeding as follows

1. Remove the push rod.
2. Remove the brake line from the master cylinder. Cover the open end of the line with tape.
3. Remove the nuts and bolts holding the master cylinder in place and slide the unit out.
4. Remove rubber boot and circlip.
5. Thoroughly clean the outside of the master cylinder, then remove the cover and drain all the brake fluid.
6. Pull out piston, spring and valve, remove primary and secondary cup from the piston.
7. After disassemble the master cylinder, clean all parts in alcohol and dry it with compressed air.

8. Inspect the piston for scoring and corrosion. If either condition is excessive, replace with a new piston.
9. If the cylinder bore is rough, it should be honed out or replace it.
10. Clean out the cylinder with alcohol and with a wire passed through the parts.
11. Clean all the parts with fresh brake oil and assemble the master cylinder.
12. Insert primary and secondary cup on piston.
13. Install a valve assembly, return spring and piston.
14. Fill up little brake oil in reservoir and pump up the piston with the help of screw driver to ensure its free travel throughout its travel.
15. Assemble rest of the parts and mount the master cylinder on the chassis, fix up linkages, pipes and fill up brake oil in reservoir.

Adjustments of brakes

There should be at least 12.7mm, or as recommended by the company, free pedal travel before the braking action takes place.

Brake adjustment procedure is as follows

1. Raise the vehicle until the wheels are off the floor.
2. With a wrench loosen the lock nut for the forward brake shoe and hold it.
3. With another wrench turn the eccentric towards the front of the vehicle until the brake shoe strike the drum.
4. While turning the wheel with one hand, release eccentric until the wheel turns freely.
5. Hold the eccentric in position and fasten the lock nut.
6. Repeat this operation to adjust the reverse shoe, but only turn the eccentric towards the back of the vehicle.
7. Do this on all four brakes. Check the fluid level in the master cylinder.

Suspension system

Repair and maintenance of leaf spring

Leaf springs generally give trouble free service but sometimes due to overloading, rough driving or driving on a bad road they get broken.

In case of a broken leaf, it will be necessary to remove the spring assembly from the chassis. On removing the centre bolt, the leaf can be separated and the broken leaf replaced. Do not forget to apply graphite greases in between spring leaves and assemble the same with bolt.

Sometimes due to continuous use, the spring assembly gets sagged or gets straightened under these circumstances, remove the spring assembly, dismantle the leaf spring and hammer each leaf spring throughout its length one by one on anvil which will give desired curve. This hammering of each leaf is called cambering of springs.

In case of replacing the broken leaf from a spring assembly which gone flat, it is necessary to camber rest of the springs also as stated above. It should, however be noted that while cambering one spring assembly it is very necessary to camber the opposite side of spring assembly also failing which the vehicle will remain tilted to one side.

Here is a list of defects which may occur in the springs

1. Vehicle out of level due to broken or flattened spring.
2. Low fender due to broken or weak spring.
3. Wrong shackle position due to weak spring.
4. Broken shackle.
5. Cracked leaves.
6. Damaged rubber bumper.
7. Sagged spring hits bottom of the frame.
8. Helpers contact too soon.
9. Loose eyes.
10. Wrapped up spring.
11. Worn bushing in master leaf.
12. Defective or worn-out 'U' bolts.
13. Loose or worn axle clips.
14. Shared or broken centre bolt.
15. Shifted leaves.
16. Broken rebound clip.

Service of Steering System

To avoid very heavy tire wear, and proper running of motor vehicle on the roads, all parts of the steering assembly should be kept in good condition. There should be no loose parts and wrong adjustments, requiring correct overhauling of servicing, repair and adjustment of the steering assembly.

Procedure for the steering system servicing has been explained

Removing the linkages

1. The steering wheel is removed by using a puller.
2. Disconnect the drop arm from the rocker shaft.
3. Disconnect the pitman arm from the relay rod.
4. Disconnect the tie rod from relay rod and knuckle arm.
5. Disconnect the drag link from knuckle arm.
6. Disassembly of idler arm bracket.

Overhauling the steering gear (Rack and Pinion Type)

1. Clamp gear housing in vise. Before disassembly, remove all dirt, oil etc.
2. Loosen the lock nut and place the match marks on the tie rod and rack end.
3. Remove the tie rod and lock nuts.
4. Remove the rack boots.
5. Using a hammer and screwdriver or chisel loosen the crimped part of the claw washer.
6. Remove the claw washer.
7. Remove the rack guide spring cap lock nut and remove the spring and rack guide.
8. Remove the pinion bearing adjusting screw.
9. Remove pinion with upper bearing.
10. Remove the rack from the pinion side without revolving it.
11. All parts are clean with kerosene. Then inspect all the parts.

12. Check rack for run out and for teeth wear or damage.
Maximum run out: 0.3 mm. if it is faulty, replace it.
13. Check the pinion for rear and tear.
14. All parts are reassembling with respective place. Then adjust the pinion preload.

9.8 Testing the Engine with the Help of Engine Analyzer

Engine analyzer main uses are measure and display of battery voltage, cranking voltage and current, charging voltage and current, coil condition, ignition system (HT coil volts for each cylinder), Dwell angle and advance angles, power balance, engine rpm, compression ratio etc. it helps keep engine of vehicles fine tune, increase fuel efficiency and performance standard of vehicles.

Engine analyzer includes oscilloscope and other instruments for making test of the engine parts and systems. It is very useful complete engine analysis in a very short time.

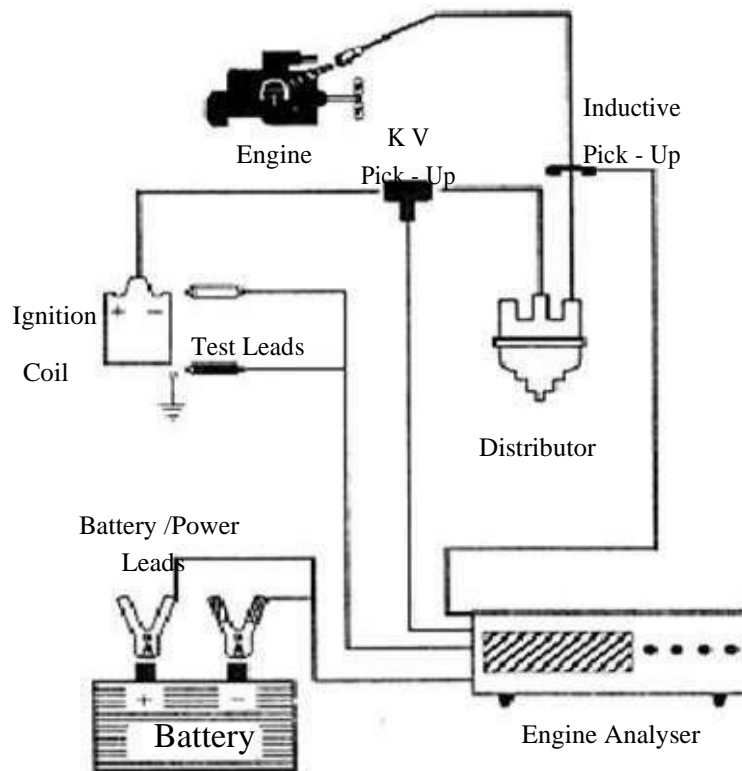

Fig 9.2 Engine Analyser

There are also testers that run many of the tests almost automatically. They produce a printed record of the tests and the test result.

Some cars have a socket, or diagnostic connector, wired to the various components in the automobile. For a diagnostic check of the components, special computerized test equipment is required. It includes a plug that can be inserted into the car socket to complete connections between the car components and the test equipment. All leads are attached by inserting each polarized plug into its matching socket and then tightening the metal cover the socket threads.

General lead hook up connections apply to all tests. The lead connections should be given properly.

9.9 Alignments of Wheels

It is used to inspect and repair the wheel geometry. It is equipped with pre-alignment inspection check, self diagnostics to enable quick detection of errors, and on screen real time adjustment for high precision and speed.

Every vehicle manufacturer furnishes the wheel alignment specification for the vehicles manufactured by him.

Measurement and adjusting the wheel alignment angles conforming to the above specified value is called the wheel alignment.

Wheel alignment angles are

- (i) Wheel angles - camber and toe.
- (ii) Steering axis angles – caster and king pin inclination.
- (iii) Unwanted angles – wheel run out and set back.

Each wheel alignment angle has a specific purpose and function. If they are not set properly. The effects will be uneven tire wear, loss of steering control, pulling to one side while driving, jerking on travel etc.

It may not be possible to correct all the above angles in a vehicle. Depending upon the design of suspension, some angles are adjustable at workshop level and some are unadjustable.

Description of equipment : The system consists of main cabinet, electronic unit, power supply unit, display panel, membrane keyboard, sensor arms and printer.

1. Main cabinet : It is the housing for the electronic unit and power supply unit. The sensor arms are fixed to the pins provided in the sides of the main cabinet.

2. Display panel : It consists of three display windows and membrane keyboard. The centre window displays the ongoing programmers the left and right windows display the respective alignment angles that are being checked.

3. Membrane keyboard : This consists of two sections. One section contains the display windows; the other section contains the operational keys for the selection and operation of various functions of the system.

4. Sensor arms : The sensor arms (left and right) contain high precision electronic sensing elements require and transmit the various alignment parameters to the electronic unit. These arms are fixed with spirit level.

5. Wheel brackets : Brackets will be mounted on the left and right wheel rims. The sensor arms will be mounted on these wheel brackets.

6. Rear wheel size : These are used as a reference for centering the front wheels with respect to the geometric centre line of the vehicle.

7. Rotary plates : The rotary plate consists of a freely rotating plate in which degree graduations are marked to measure the angle of rotation. While carrying out alignment, the wheels of the vehicle being aligned will rest of these plates. The rotary plates enable left 20 degree and right 20 degree movement required for measuring caster angle.

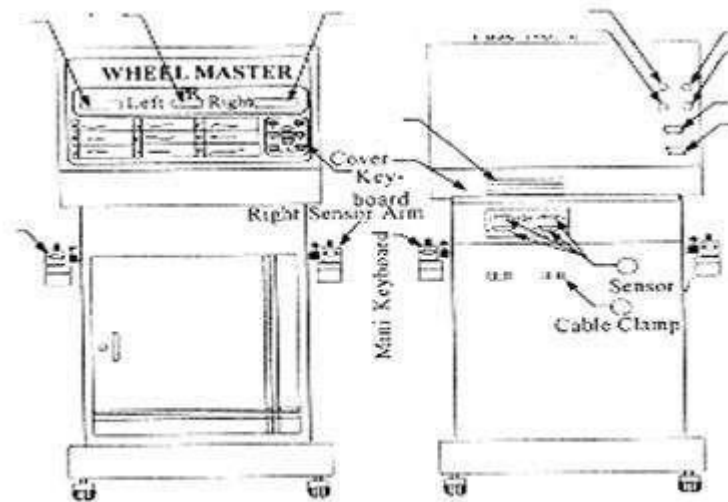

Fig 9.3 Wheel Aligner

8. Steering lock : It is used lock the steering wheel movement, while performing the toe adjustment.

9. Brake pedal lock : It is to keep the brake in pressed condition, so that the vehicle will not move during the turn left 20 degree and turn right 20 degree programs.

9.10 Balancing of wheels

Modern suspension systems and higher driving speeds have made it necessary that the wheel and tire assembly be in balance if maximum driving and riding comfort, maximum safety, and maximum tire life are to be realized. Front wheels are more sensitive to an unbalanced condition than the rear wheels, but all four should be balanced to prolong tire life.

A wheel and tire assembly can be balanced in two ways statically and dynamically. Static imbalance is indicated by 'wheel tramp'. Dynamic imbalance will cause the wheel to wobble or shimmy. Either type of imbalance can exist without the other, although both tires are usually present at the same time.

Wheel balance should be checked at regular intervals, and also a tire has been repaired, retreaded, or recapped.

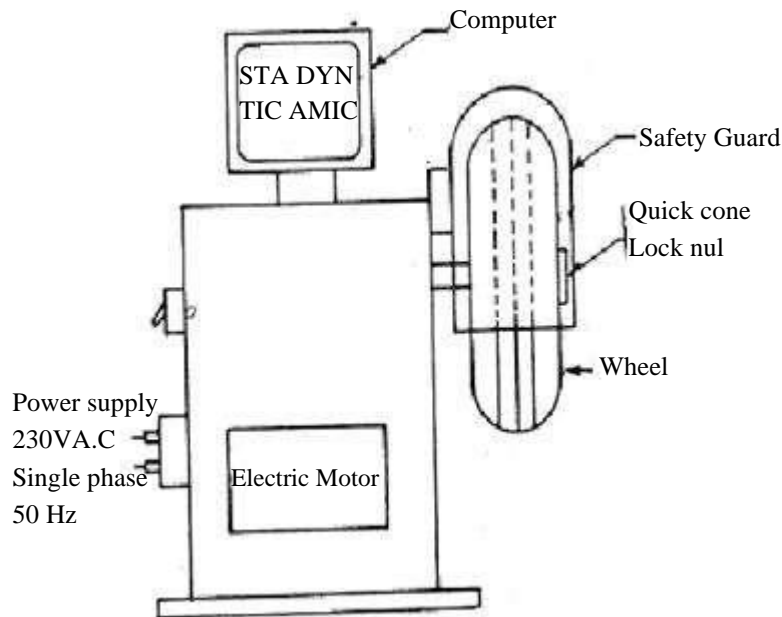

Fig 9.4 Wheel Balancer

Computerized wheel balances are used to check the wheel balancing. It is used to check the single plane (static) and two plane (dynamic) balancing. Balancer has a spindle driven by an electrical motor.

Attach the wheel to the balancer spindle with the help of quick cone lock nut. Quick cone lock nut – ensures fast mounting and removal of wheel. Spin the wheel at high speed, the computer displays unbalance for inner and outer rims in single run. Determine the size of weights needed. Self checking, on error line program facilities are available in this balancer. Measuring range of this balancer is 0-200gms and balancing speed 400 rpm.